



# Optics and Photonics

## Lecture 04: Stimulated Emission Devices: Optical Amplifiers and LASERS

---

Dr. Hien PHAN

Department of Space and Applications (DSA)  
University of Science and Technology of Hanoi (USTH)



# Stimulated Emission Devices Optical Amplifiers and LASERS



Zhores Alferov (on the right) with Valery Kuzmin (technician) in 1971 at the Ioffe Physical Technical Institute, discussing their experiments on heterostructures. Zhores Alferov carried out some of the early pioneering work on heterostructure semiconductor devices that lead to the development of a number of important optoelectronic devices, including the heterostructure laser. Zhores Alferov and Herbert Kroemer shared the Nobel Prize in Physics (2000) with Jack Kilby. Their Nobel citation is "*for developing semiconductor heterostructures used in high-speed- and opto-electronics*" (Courtesy of Zhores Alferov, Ioffe Physical Technical Institute)

# The Laser Patent Wars



Arthur L. Schawlow is adjusting a ruby optical maser during an experiment at Bell Labs, while C.G.B. Garrett prepares to photograph the maser flash. In 1981, Arthur Schawlow shared the Nobel Prize in Physics for his "contribution to the development of laser spectroscopy" (Courtesy of Bell Labs, Alcatel-Lucent)



Gordon Gould (1920–2005) obtained his BSc in Physics (1941) from Union College in Schenectady, and MSc from Yale University. Gould came up with the idea of an optically pumped laser during his PhD work at Columbia University around 1957. He is now recognized for the invention of optical pumping as a means of exciting masers and lasers. He has been also credited for collisional pumping as in gas lasers, and a variety of application-related laser patents. After nearly three decades of legal disputes, in 1987, he eventually won rights to the invention of the laser. Gould's laboratory logbook even had an entry with at he heading "Some rough calculations on the feasibility of a LASER: Light Amplification by Stimulated Emission of Radiation," which is the first time that this acronym appears. Union College awarded Gould an honorary Doctor of Sciences in 1978 and the Eliphalet Nott Medal in 1995.



# Stimulated Emission Devices

## Optical Amplifiers and LASERS

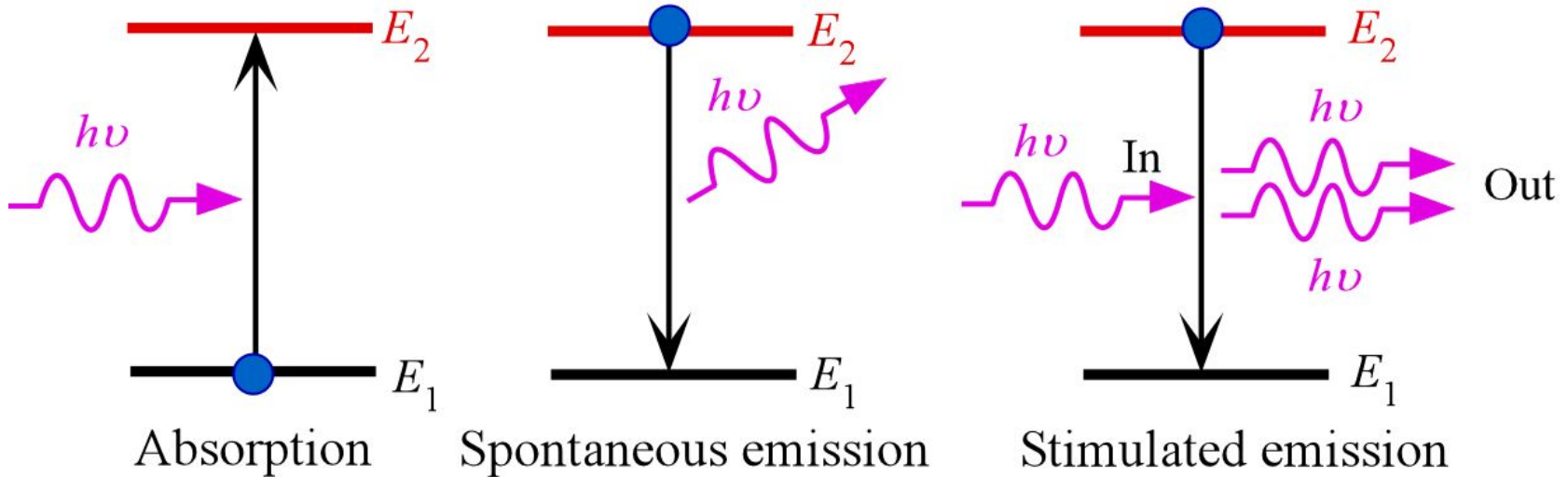



# The LASER Principle

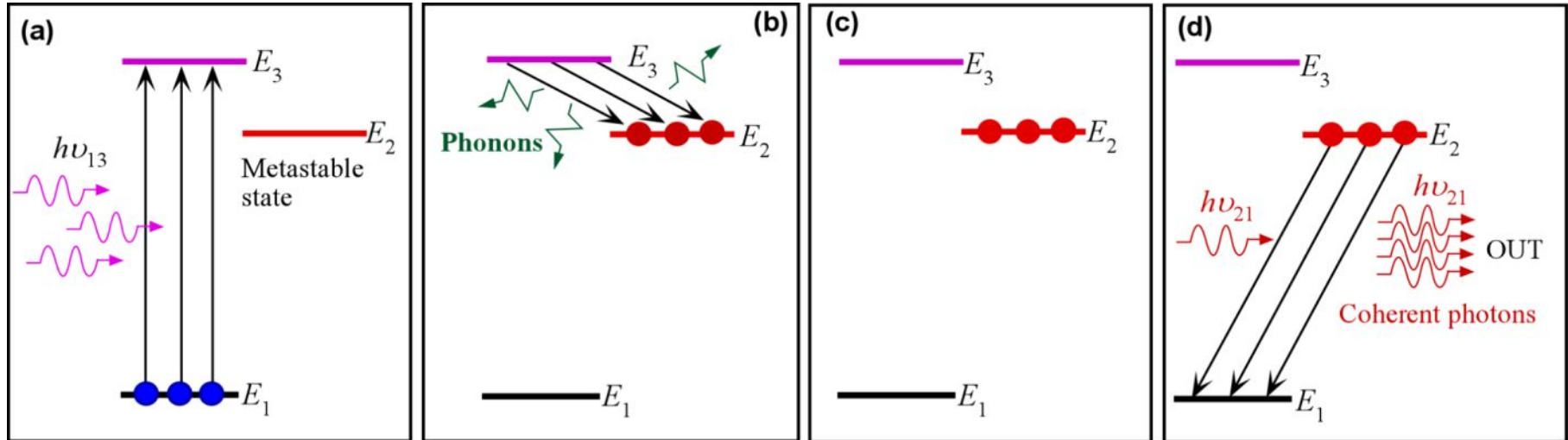

The principle of the LASER, using a ruby laser as an example. (a) The ions ( $\text{Cr}^{3+}$  ions) in the ground state are pumped up to the energy level  $E_3$  by photons from an optical excitation source. (b) Ions at  $E_3$  rapidly decay to the long-lived state at the energy level  $E_2$  by emitting lattice vibrations (phonons). (c) As the states at  $E_2$  are long-lived, they quickly become populated and there is a population inversion between  $E_2$  and  $E_1$ . (d) A random photon (from spontaneous decay) of energy  $h\nu_{21} = E_2 - E_1$  can initiate stimulated emission. Photons from this stimulated emission can themselves further stimulate emissions leading to an avalanche of stimulated emissions and coherent photons being emitted.

# 3-Level Lasers: The Ruby Laser

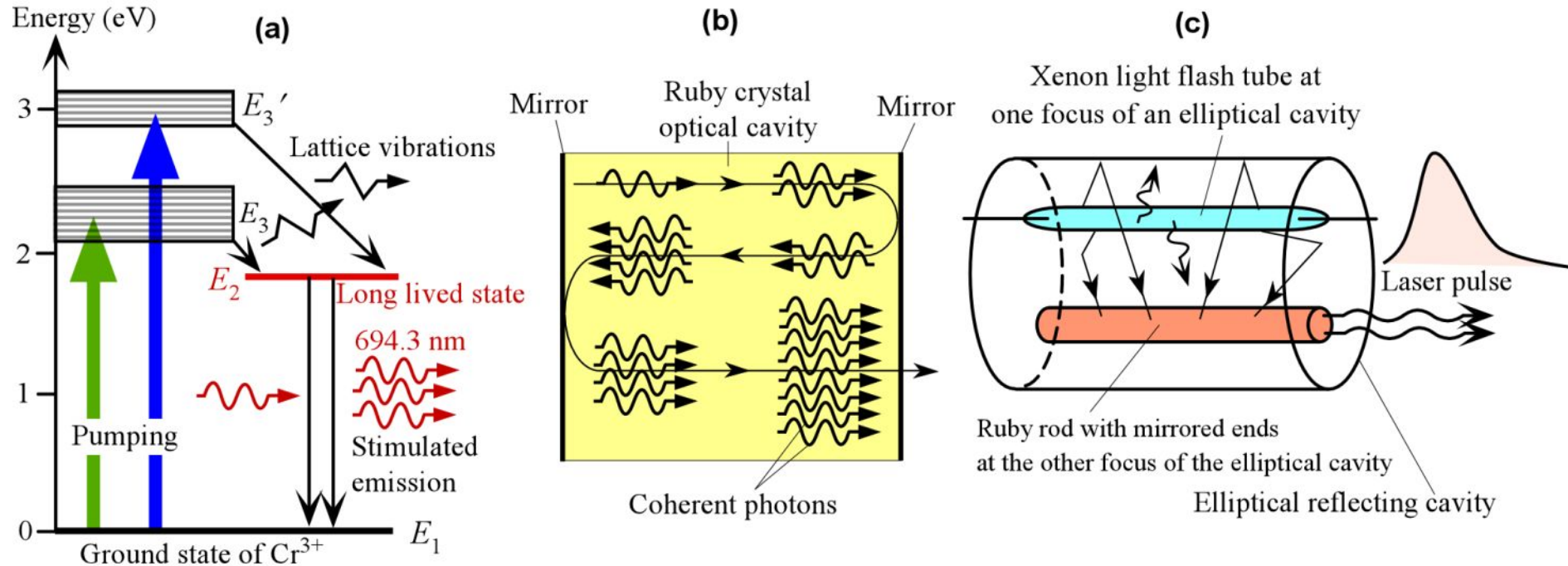

(a) A more realistic energy diagram for the  $\text{Cr}^{3+}$  ion in the ruby crystal ( $\text{Al}_2\text{O}_3$ ), showing the optical pumping levels and the stimulated emission. (b) The laser action needs an optical cavity to reflect the stimulated radiation back and forth to build-up the total radiation within the cavity, which encourages further stimulated emissions. (c) A typical construction for a ruby laser, which uses an elliptical reflector, and has the ruby crystal at one focus and the pump light at the other focus.



# 3-Level Lasers: The Ruby Laser

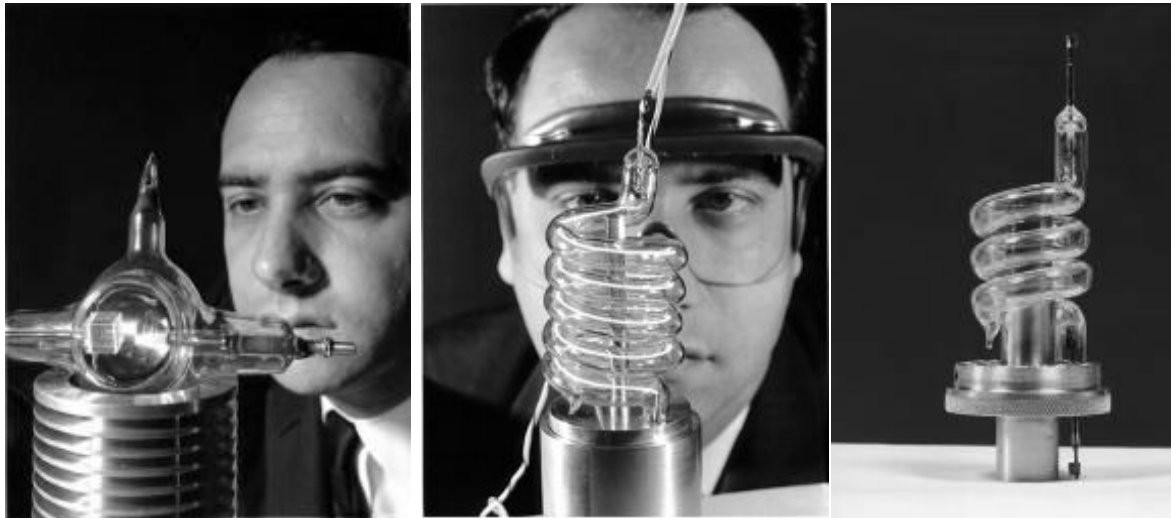

Theodore Harold Maiman was born in 1927 in Los Angeles, son of an electrical engineer. He studied engineering physics at Colorado University, while repairing electrical appliances to pay for college, and then obtained a Ph.D. from Stanford. Theodore Maiman constructed this first laser in 1960 while working at Hughes Research Laboratories (T.H. Maiman, "Stimulated optical radiation in ruby lasers", *Nature*, **187**, 493, 1960). There is a vertical chromium ion doped ruby rod in the center of a helical xenon flash tube. The ruby rod has mirrored ends. The xenon flash provides optical pumping of the chromium ions in the ruby rod. The output is a pulse of red laser light. (Courtesy of HRL Laboratories, LLC, Malibu, California.)



# 4 Level Laser System

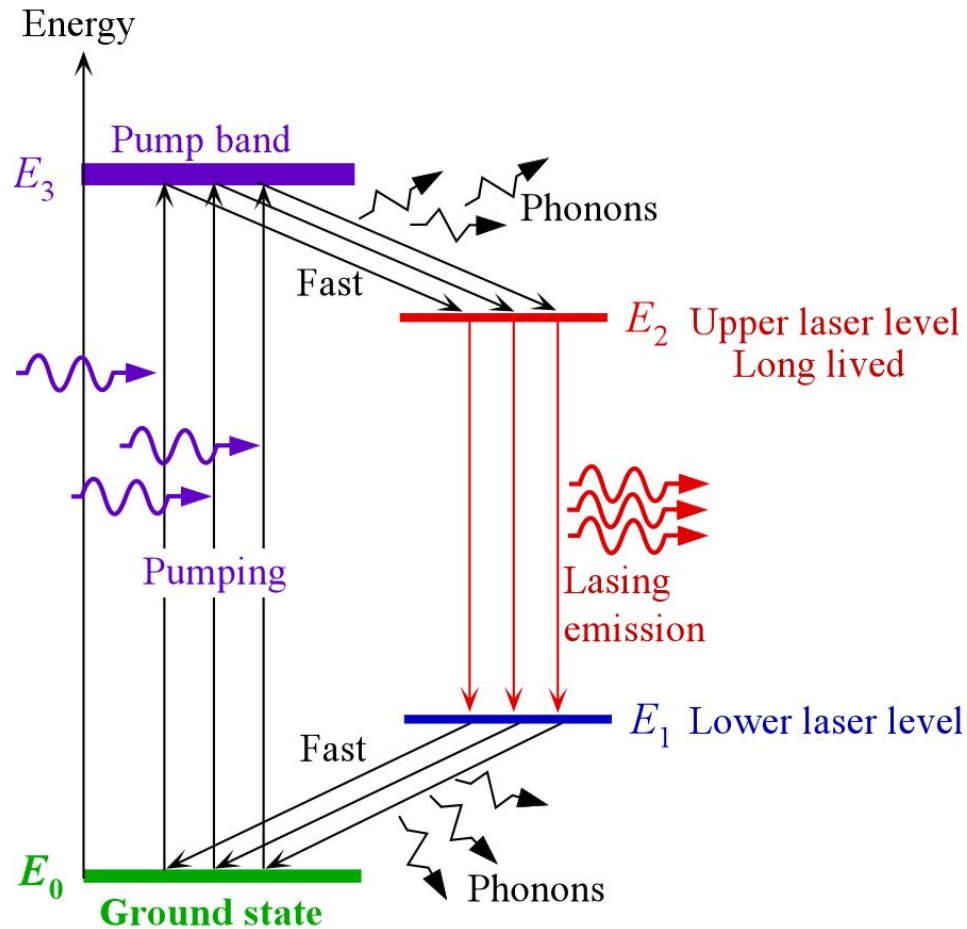

A four energy level laser system  
Highly simplified representation of  $\text{Nd}^{3+}:\text{YAG}$  laser



# Einstein Coefficients

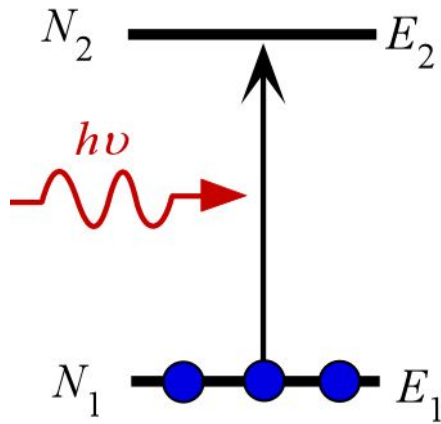

(a) Absorption

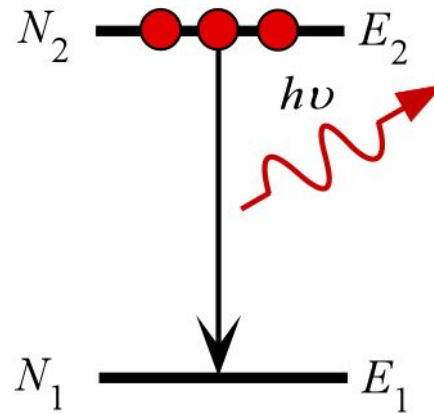

(b) Spontaneous emission

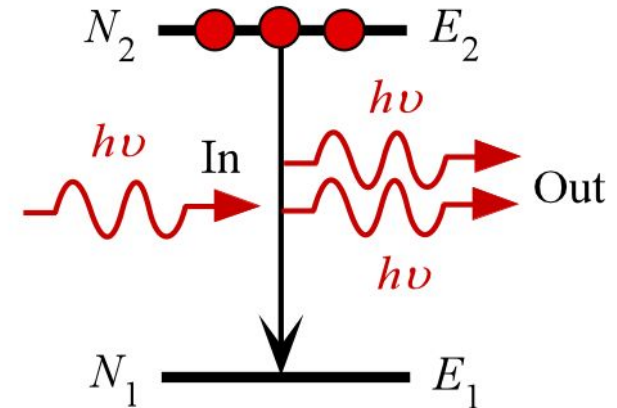

(c) Stimulated emission

$$R_{12} = \underbrace{B_{12} N_1 \rho(\nu)}_{\text{Absorption}}$$

$\uparrow$   
 $-dN_1/dt$

$$R_{21} = \underbrace{A_{21} N_2}_{\text{Spontaneous emission}} + \underbrace{B_{21} N_2 \rho(\nu)}_{\text{Stimulated emission}}$$

$\uparrow$   
 $-dN_2/dt$

We need  $A_{21}$ ,  $B_{12}$  and  $B_{21}$

# Einstein Coefficients

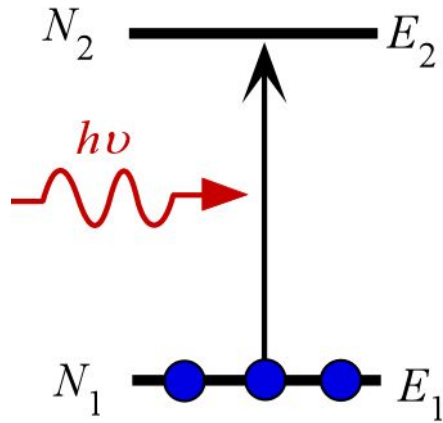

(a) Absorption

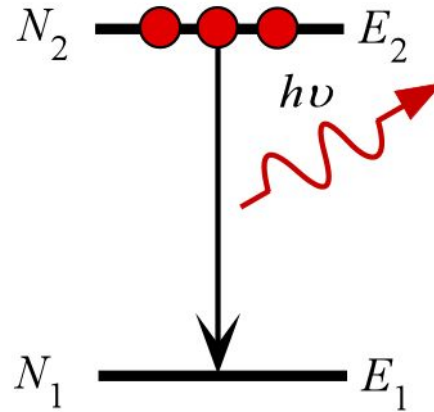

(b) Spontaneous emission

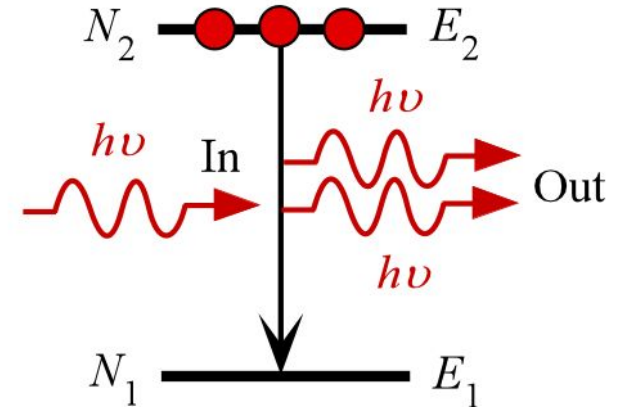

(c) Stimulated emission

Consider equilibrium

$$R_{12} = R_{21}$$

Boltzmann statistics

$$N_2 / N_1 = \exp[-(E_2 - E_1)/k_B T]$$

*E<sub>1</sub> and E<sub>2</sub> have the same degeneracy*

Planck's black body radiation law

$$\rho_{\text{eq}}(\nu) = \frac{8\pi h \nu^3}{c^3 \left[ \exp\left(\frac{h\nu}{k_B T}\right) - 1 \right]}$$



# Einstein Coefficients

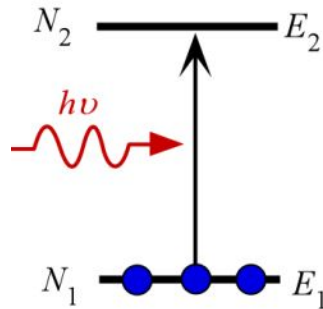

(a) Absorption

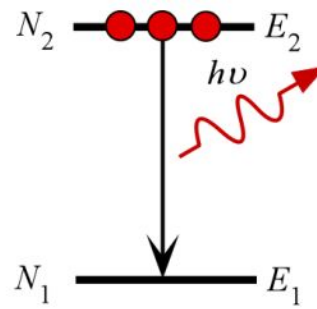

(b) Spontaneous emission

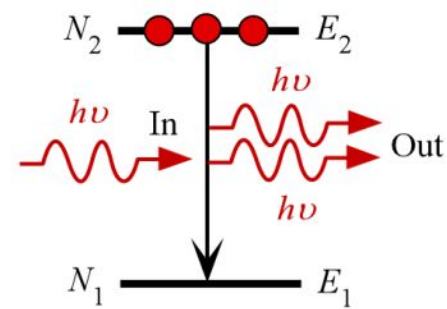

(c) Stimulated emission

$$B_{12} = B_{21}$$

$$A_{21}/B_{21} = 8\pi h\nu^3/c^3$$

$$\frac{R_{21}(\text{stim})}{R_{21}(\text{spon})} = \frac{B_{21}N_2\rho(\nu)}{A_{21}N_2} = \frac{B_{21}\rho(\nu)}{A_{21}} = \frac{c^3}{8\pi h\nu^3} \rho(\nu)$$

$$\frac{R_{21}(\text{stim})}{R_{12}(\text{absorp})} = \frac{N_2}{N_1}$$



# LASER Requirements

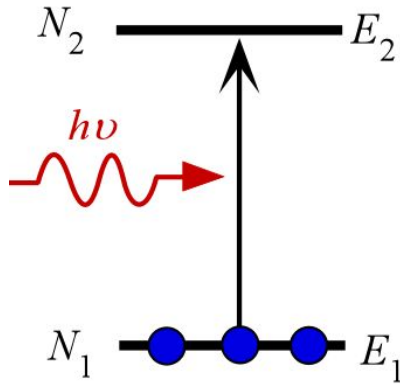

(a) Absorption

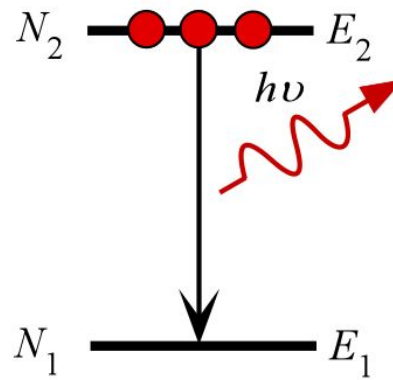

(b) Spontaneous emission

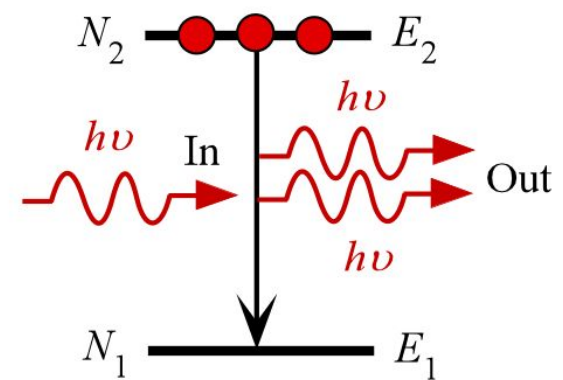

(c) Stimulated emission

$$\frac{R_{21}(\text{stim})}{R_{12}(\text{absorp})} = \frac{N_2}{N_1}$$

**Population inversion**

$$\frac{R_{21}(\text{stim})}{R_{21}(\text{spon})} \propto \rho(\nu)$$

**Optical cavity**



# Spontaneous Decay Time

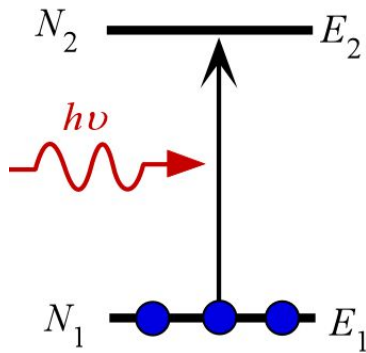

(a) Absorption

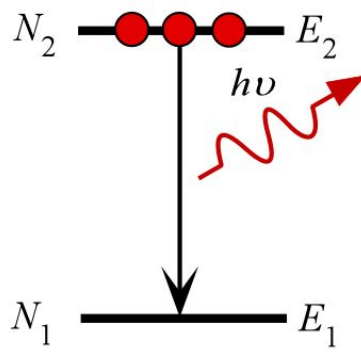

(b) Spontaneous emission

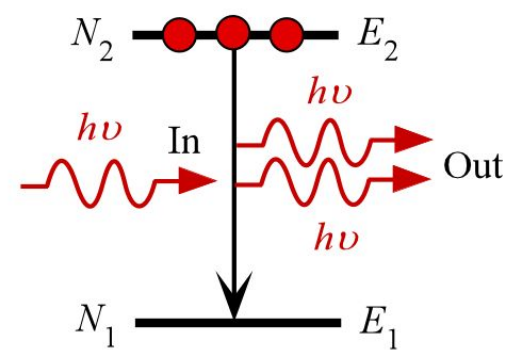

(c) Stimulated emission

$$R_{12} = -dN_1/dt \quad \text{and} \quad R_{21} = -dN_2/dt$$

$R_{21}$  = rate at which  $N_2$  is decreasing by spontaneous and stimulated emission

Consider  $N_2$  changes by spontaneous emission

$$dN_2/dt = -A_{21}N_2 = -N_2/\tau_{sp},$$



$\tau_{sp} = 1/A_{21}$  = **spontaneous decay time**; or the **lifetime** of level  $E_2$ .

## EXAMPLE: Minimum pumping power for three level laser systems



Consider the 3-level system Figure 4.2(a). Assuming that the transitions from  $E_3$  to  $E_2$  are fast, and the spontaneous decay time from  $E_2$  to  $E_1$  is  $\tau_{sp}$ , show that the *minimum* pumping power  $P_{pmin}$  that must be absorbed by the laser medium per unit volume for population inversion ( $N_2 > N_1$ ) is

$$P_{pmin}/V = (N_0/2)h\nu_{13}/\tau_{sp} \quad \text{Minimum pumping for population inversion for 3-level laser} \quad (4.2.12)$$

where  $V$  is the volume,  $N_0$  is the concentration of ions in the medium and hence at  $E_0$  before pumping. Consider a ruby laser in which the concentration of  $\text{Cr}^{3+}$  ions is  $10^{19} \text{ cm}^{-3}$ , the ruby crystal rod is 10 cm long and 1 cm in diameter. The lifetime of  $\text{Cr}^{3+}$  at  $E_2$  is 3 ms. Assume the pump takes the  $\text{Cr}^{3+}$  ions to the  $E_3$ -band in Figure 4.3 (a), which is about 2.2 eV above  $E_0$ . Estimate the minimum power that must be provided to this ruby laser to achieve population inversion.

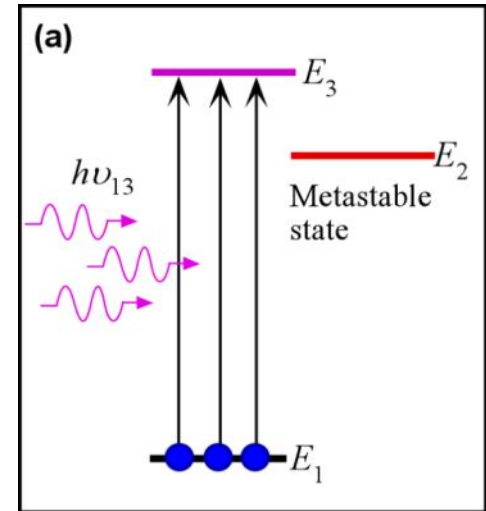

### Solution

Consider the 3-level system in Figure 4.2 (a). To achieve population inversion we need to get half the ions at  $E_1$  to level  $E_2$  so that  $N_2 = N_1 = N_0/2$  since  $N_0$  is the total concentration of  $\text{Cr}^{3+}$  ions all initially at  $E_1$ . We will need  $[(N_0/2)h\nu_{13} \times \text{volume}]$  amount of energy to pump to the  $E_3$ -band.

## EXAMPLE: Minimum pumping power for three level laser systems



### Solution (continued)

The ions decay quickly from  $E_3$  to  $E_2$ . We must provide this pump energy before the ions decay from  $E_2$  to  $E_1$ , that is, before  $\tau_{sp}$ . Thus, the *minimum* power the ruby needs to absorb is

$$P_{pmin} = V(N_0 / 2)h\nu_{13} / \tau_{sp}$$

which is Eq. (4.2.12). For the ruby laser

$$\begin{aligned} P_{pmin} &= [\pi(0.5 \text{ cm})^2(10 \text{ cm})][(10^{19} \text{ cm}^{-3})/2](2.2 \text{ eV})(1.6 \times 10^{-19} \text{ J/eV})/(0.003 \text{ s}) \\ &= 4.6 \text{ kW} \end{aligned}$$

The total pump energy that must be provided in less than 3 ms is **13.8 J**.

# Absorption Cross Section

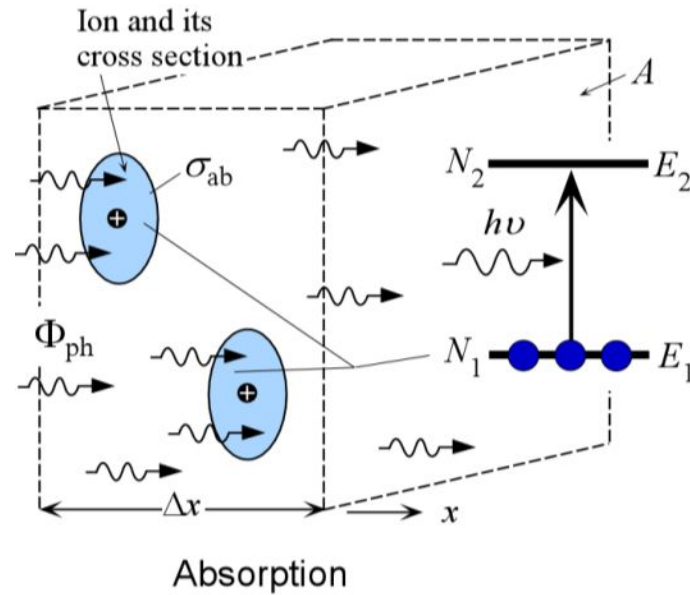

Optical power absorbed by an ion

= Light intensity  $\times$  Absorption cross section of ion

$$= I \sigma_{ab}$$

$$-\frac{\Delta I}{I \Delta x} = \sigma_{ab} N_1 = \alpha$$



# Emission Cross Section

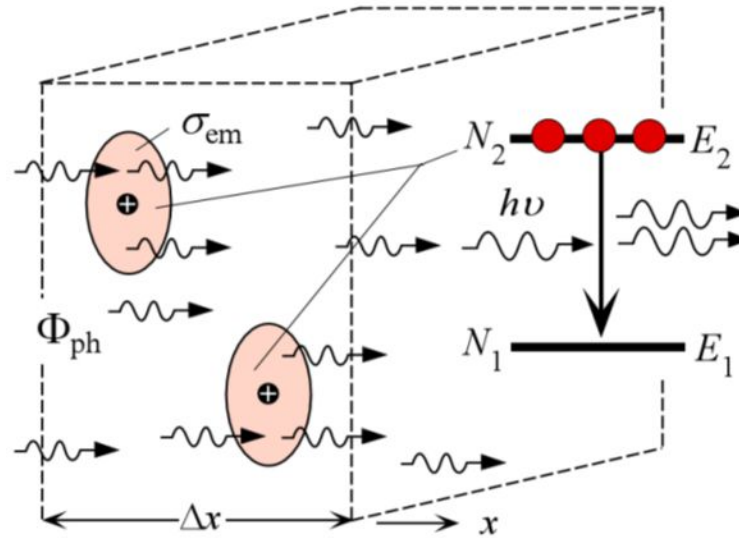

Stimulated emission

Stimulated optical power emitted by an ion

= Light intensity  $\times$  Emission cross section of ion

$$= I \sigma_{em}$$

$$\frac{\Delta I}{I \Delta x} = \sigma_{em} N_2$$



# Optical Gain Coefficient

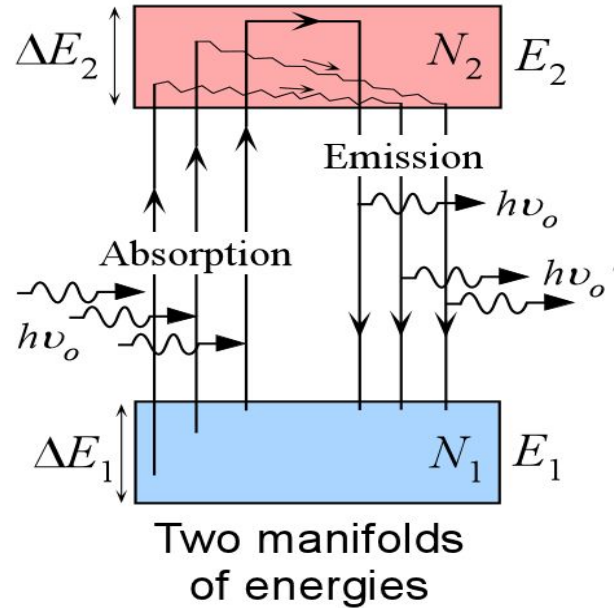

## Definition

$$g = \left[ \frac{\Delta I}{I \Delta x} \right]_{\text{net}}$$

$$g = \sigma_{\text{em}} N_2 - \sigma_{\text{ab}} N_1$$

$$g(\nu) = \sigma_{\text{em}}(\nu) N_2 - \sigma_{\text{ab}}(\nu) N_1$$

Optical gain is  $G$

$$G = \exp(gL)$$

# Erbium Doped Fiber Amplifier

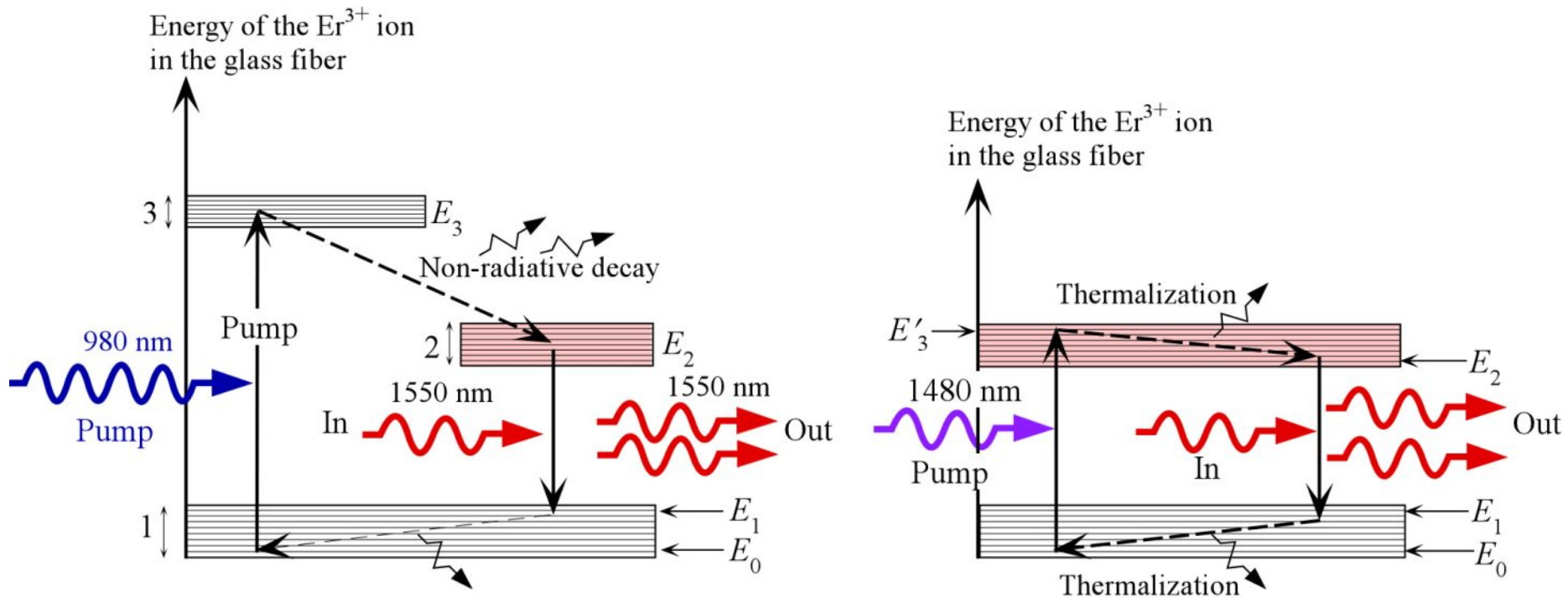

(a) Energy diagram for the  $\text{Er}^{3+}$  ion in the glass fiber medium and light amplification by stimulated emission from  $E_2$  to  $E_1$ . (Features are highly exaggerated.) Dashed arrows indicate radiationless transitions (energy emission by lattice vibrations). The pump is a 980 nm laser diode (b) EDFA can also be pumped with a 1480 nm laser diode.

# Erbium Doped Fiber Amplifier

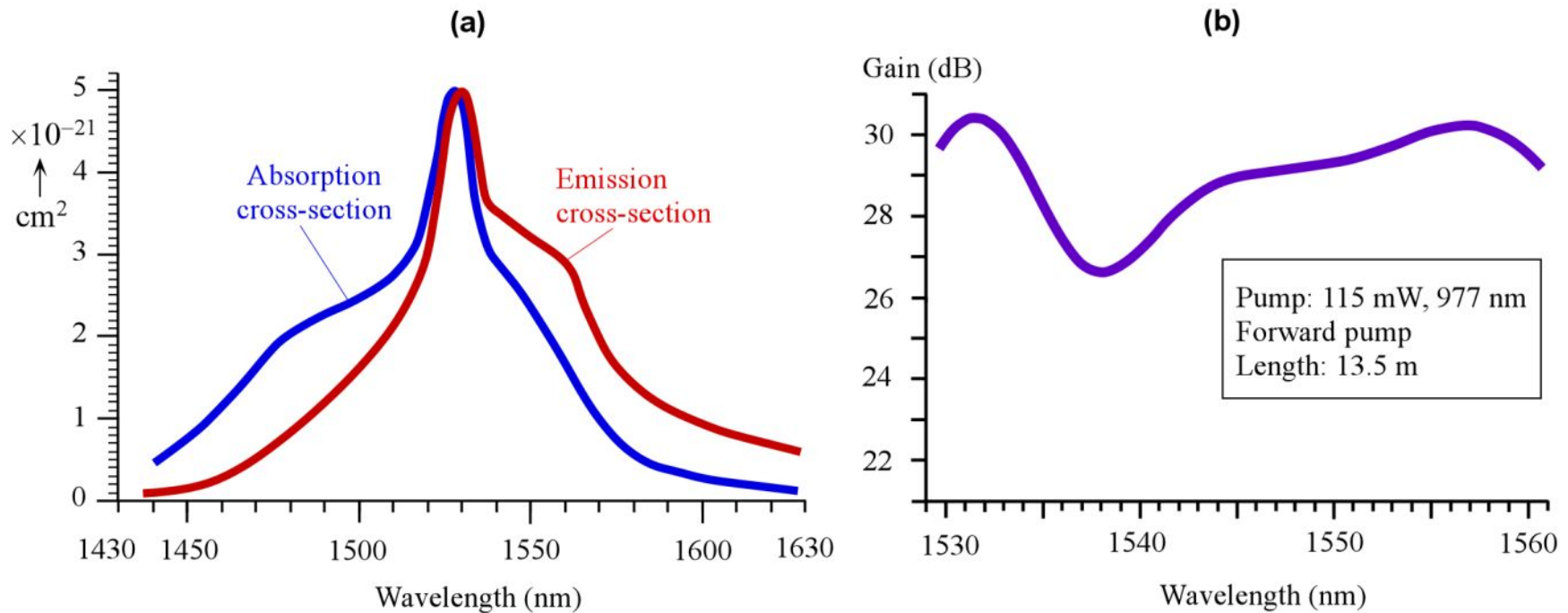

(a) Typical absorption and emission cross sections,  $\sigma_{ab}$  and  $\sigma_{em}$  respectively, for Er<sup>3+</sup> in a silica glass fiber doped with alumina (SiO<sub>2</sub>-Al<sub>2</sub>O<sub>3</sub>). (Cross section values for the plots were extracted from B. Pedersen *et al*, *J. Light. Wave Technol.* 9, 1105, 1991.) (b) The spectral characteristics of gain,  $G$  in dB, for a typical commercial EDF, available from Fibercore as IsoGain<sup>TM</sup> fiber. Forward pumped at 115 mW and at 977 nm. The insertion losses are 0.45 dB for the isolator, 0.9 dB for the pump coupler and splices.



# Erbium Doped Fiber Amplifier

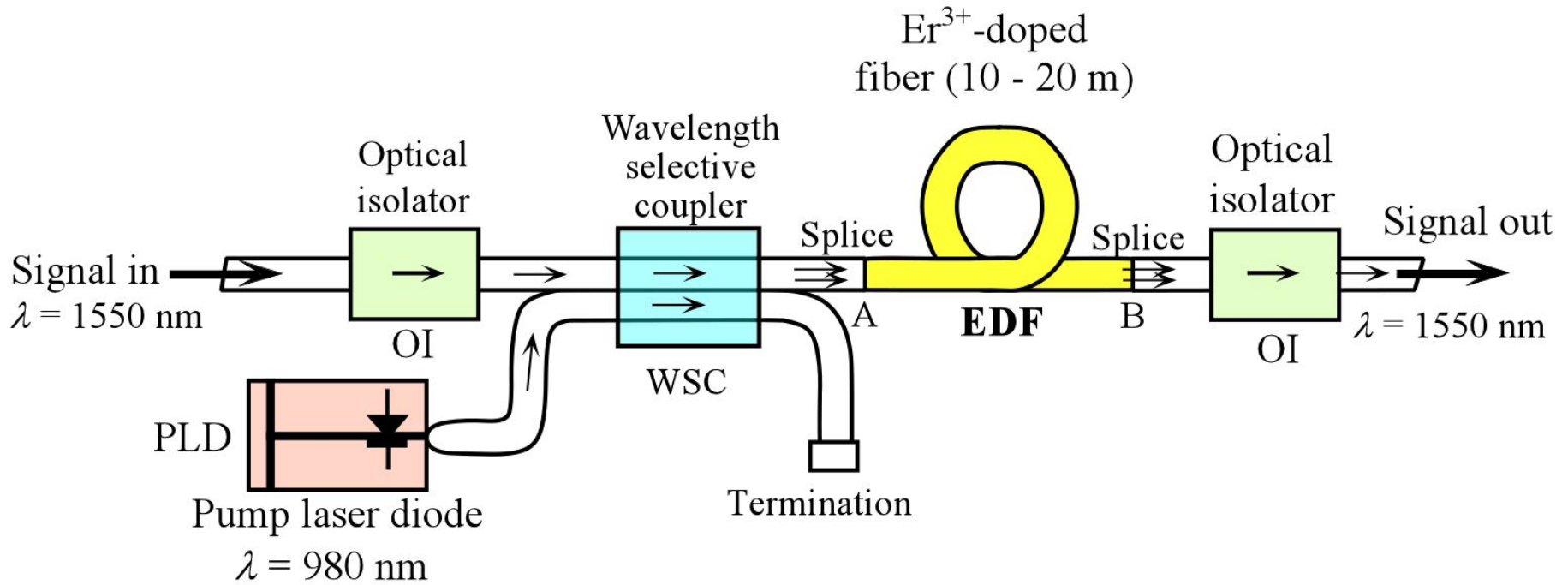



# Erbium Doped Fiber Amplifier



EDFA (Strand Mounted Optical Amplifier, Prisma 1550) for optical amplification at 1550 nm. This model can be used underground to extend the reach of networks; and operates over -40 °C to +65 °C. The output can be as high as 24 dBm (Courtesy of Cisco).



EDFAs (LambdaDriver®-Optical Amplifier Modules) with low noise figure and flat gain (to within  $\pm 1$  dB) for use in DWDM over 1528 - 1563 nm. These amplifiers can be used for booster, in-line and preamplifier applications. (Courtesy of MRV Communications, Inc)



# EDFA Configurations

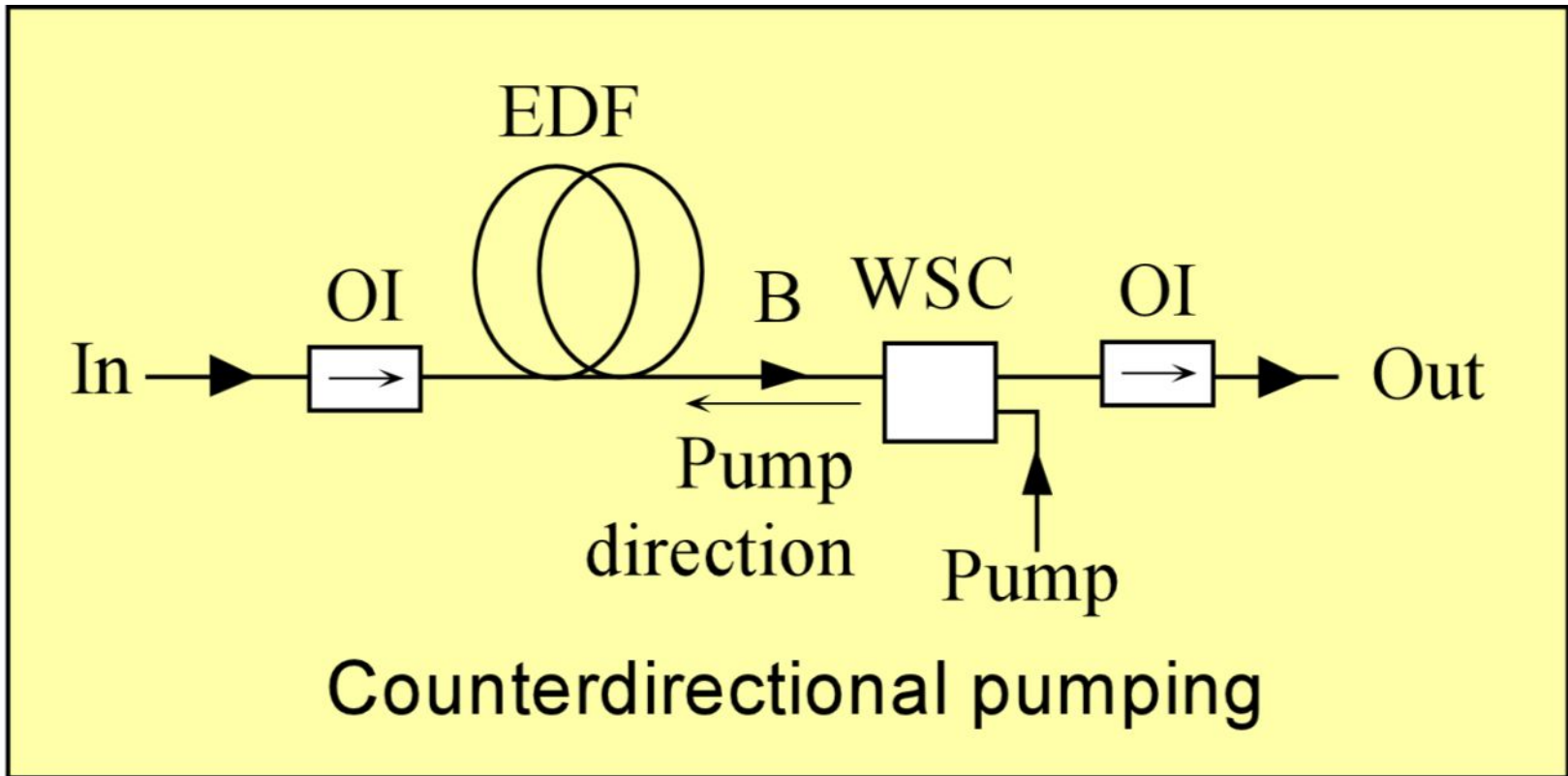



# EDFA Configurations

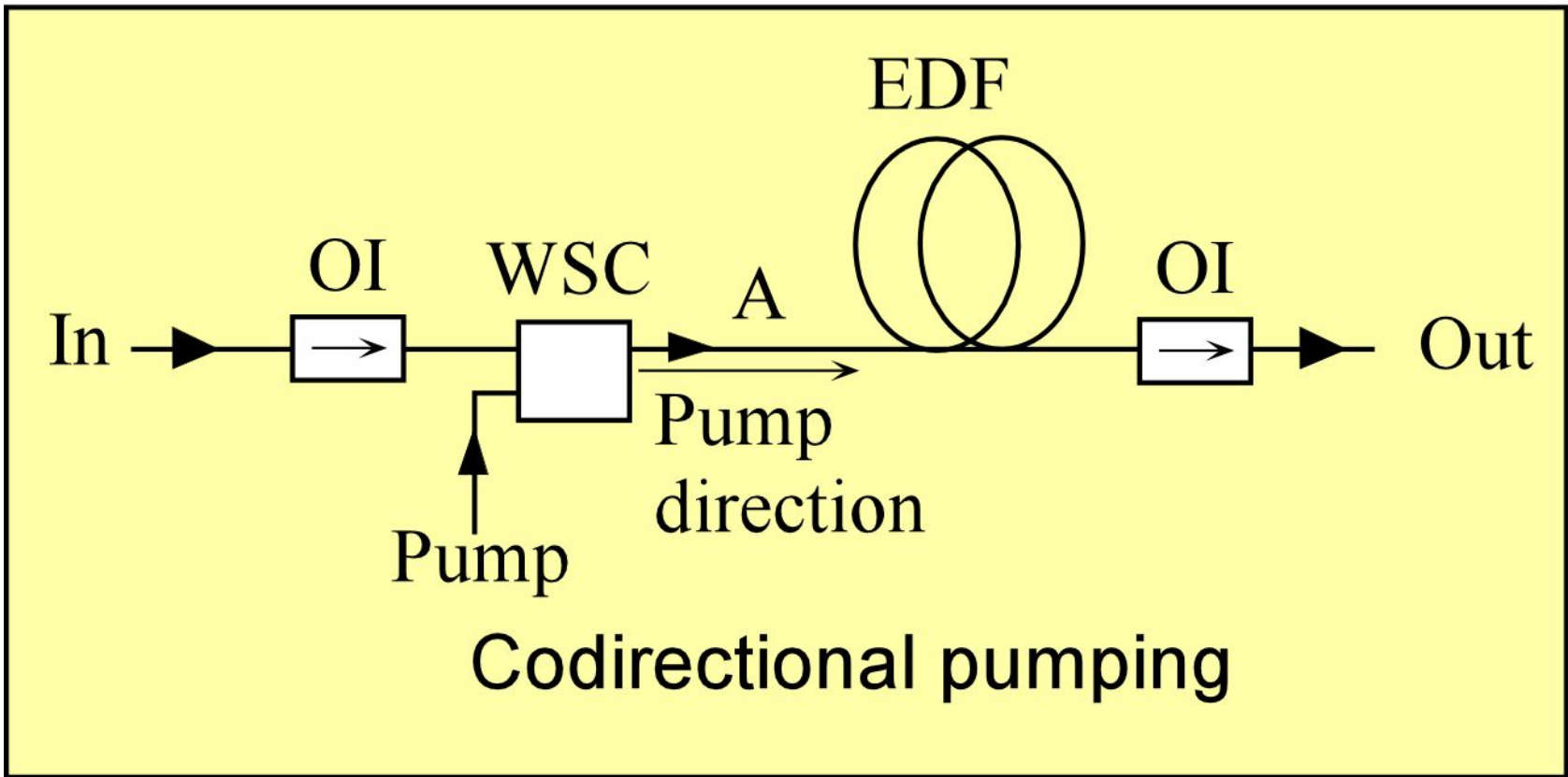





# EDFA Configurations

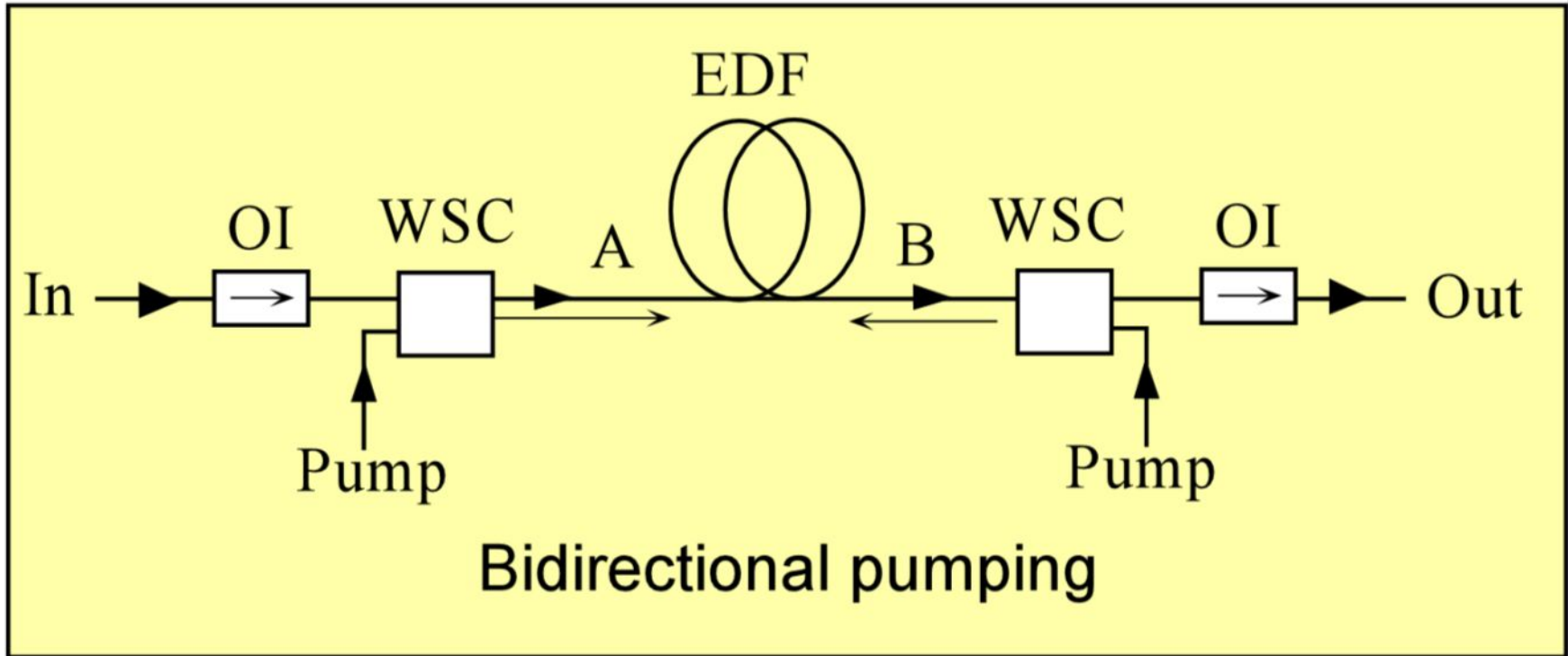



# EDFA Configurations

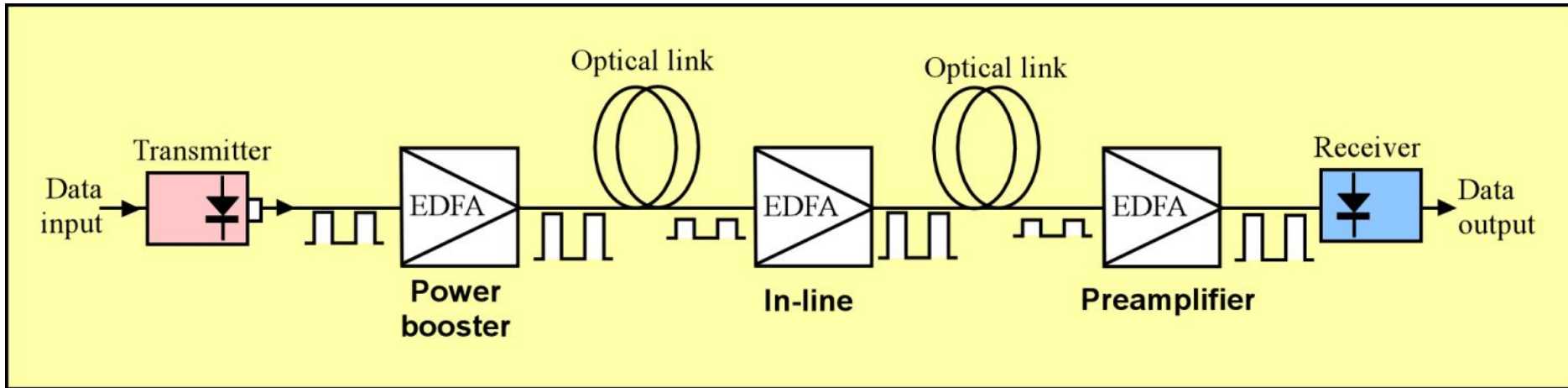

EDFAs are widely used in telecommunications as a power booster, after the transmitter, in-line amplifier within the optical link, and preamplifier before the receiver. The symbol shown for the EDFA is widely used.

# EDFA

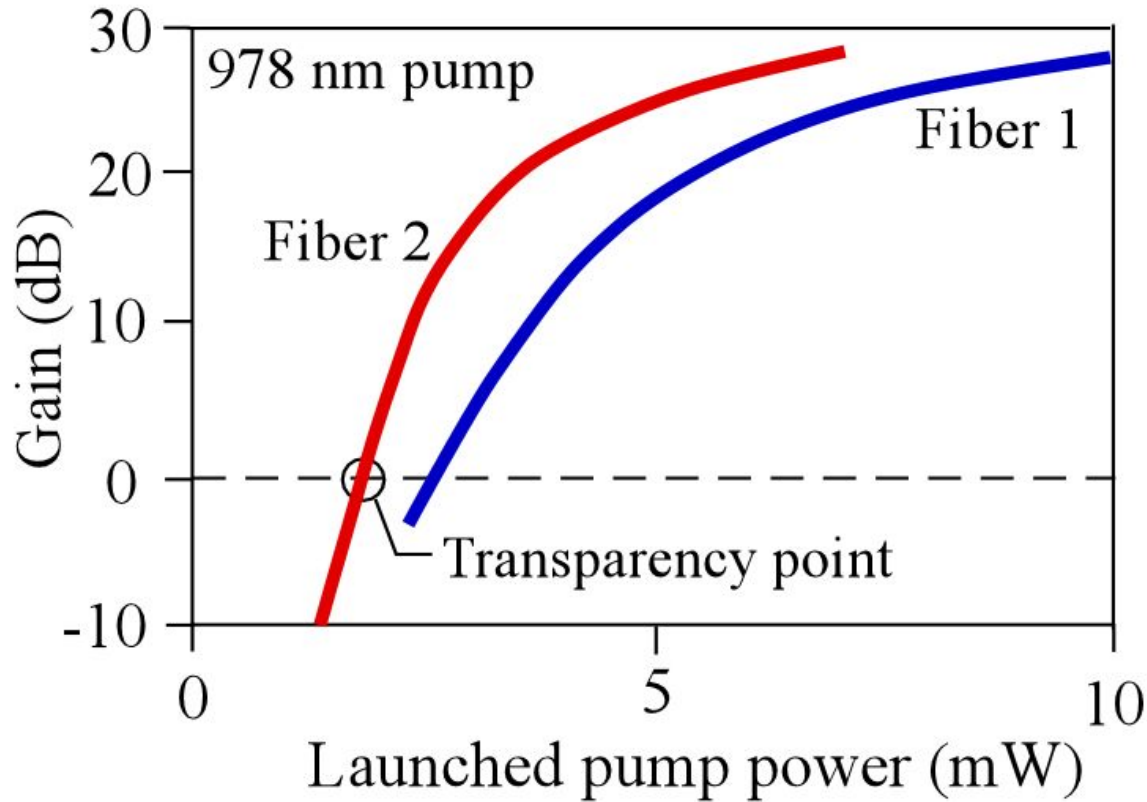

Typical characteristics of EDFA small signal gain in dB vs launched pump power for two different types of fibers pumped at 980 nm. The fibers have different core compositions and core diameter, and different lengths ( $L_1 = 19.9$  m, and  $L_2 = 13.6$  m) (Figures were constructed by using typical data from C.R. Jiles *et al*, *IEEE Photon. Technol. Letts.* 3, 363, 1991 and C.R. Jiles *et al*, *J. Light Wave Technol.* 9, 271, 1991)



# EDFA

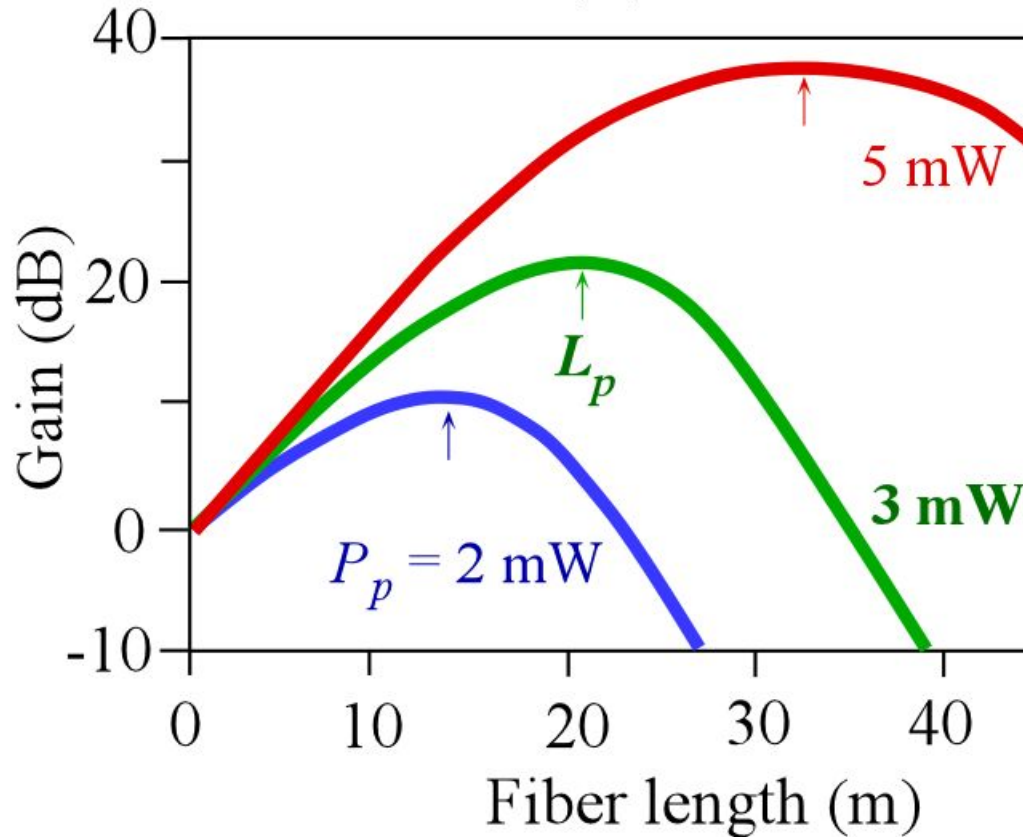

Typical dependence of small signal gain  $G$  on the fiber length  $L$  at different launched pump powers. There is an optimum fiber length  $L_p$ . (Figures were constructed by using typical data from C.R. Jiles *et al*, *IEEE Photon. Technol. Letts.* 3, 363, 1991 and C.R. Jiles *et al*, *J. Light Wave Technol.* 9, 271, 1991)

# EDFA

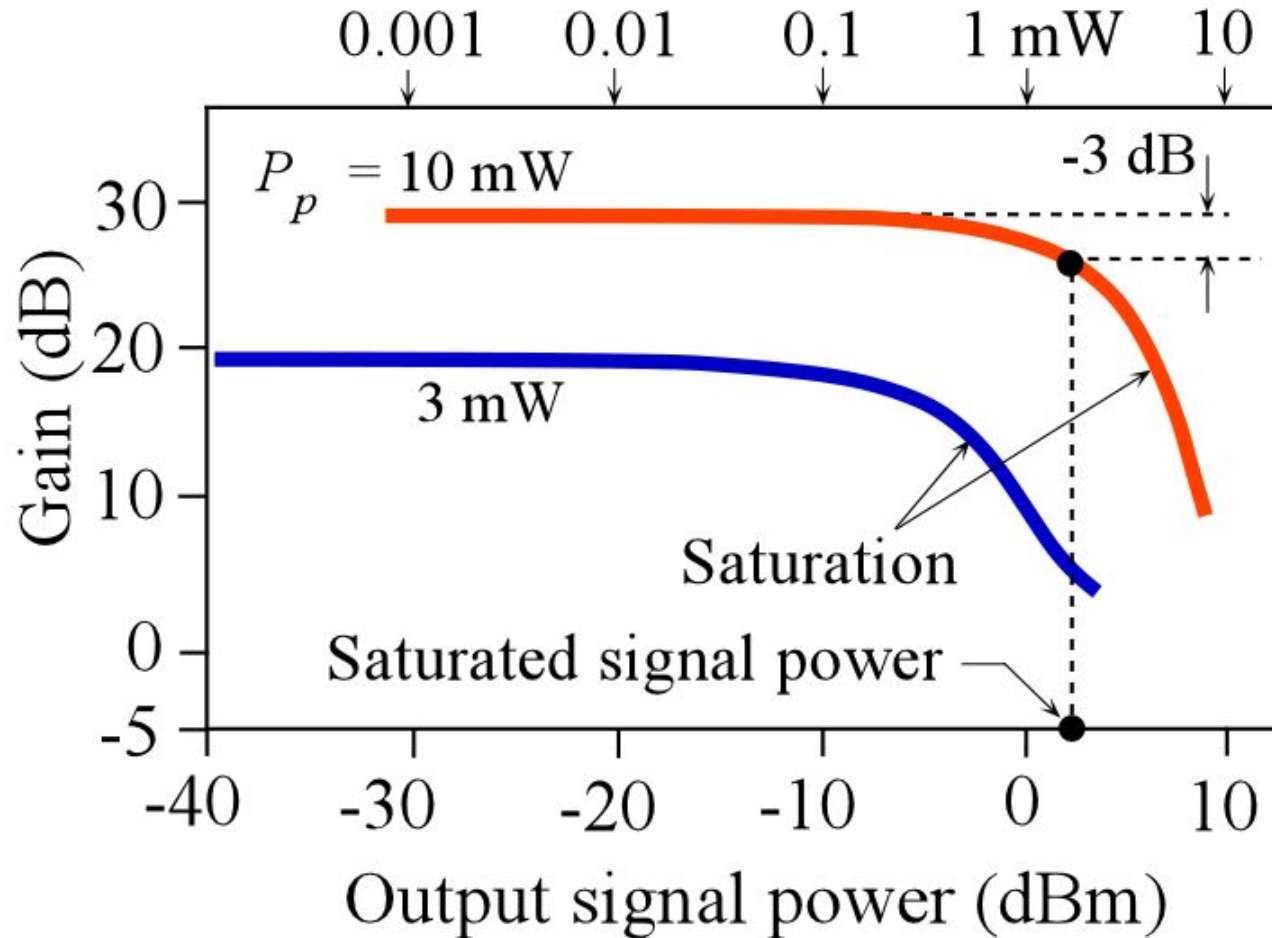

Typical dependence of gain on the output signal strength for different launched pump powers. At high output powers, the output signal saturates, *i.e.* the gain drops. (Figures were constructed by using typical data from C.R. Jiles *et al*, *IEEE Photon. Technol. Letts.* 3, 363, 1991 and C.R. Jiles *et al*, *J. Light Wave Technol.* 9, 271, 1991)

# EDFA

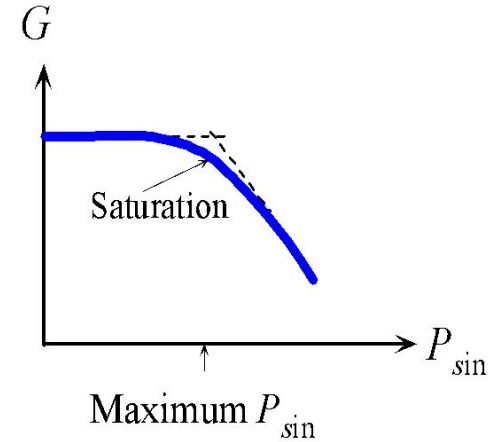
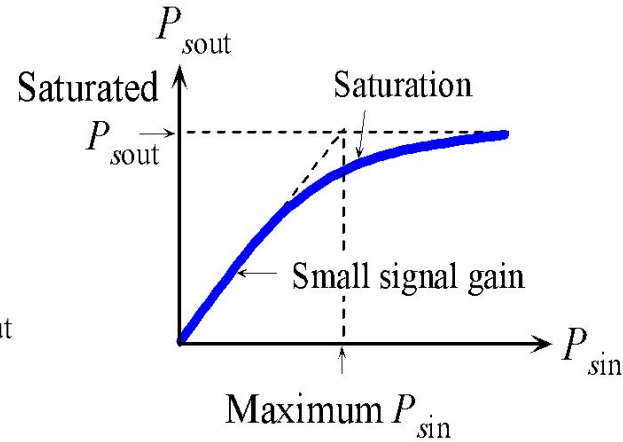
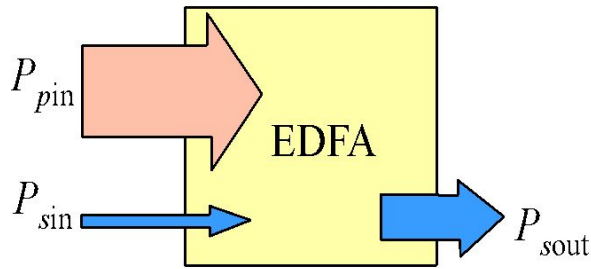

## Power Conversion Efficiency (PCE)

$$\eta_{\text{PCE}} = \frac{P_{\text{sout}} - P_{\text{sin}}}{P_{\text{pin}}} \approx \frac{P_{\text{sout}}}{P_{\text{pin}}}$$

$$\eta_{\text{PCE}} \approx \frac{\Phi_{\text{sout}}}{\Phi_{\text{pin}}} \times \frac{\lambda_p}{\lambda_s}$$

# EDFA

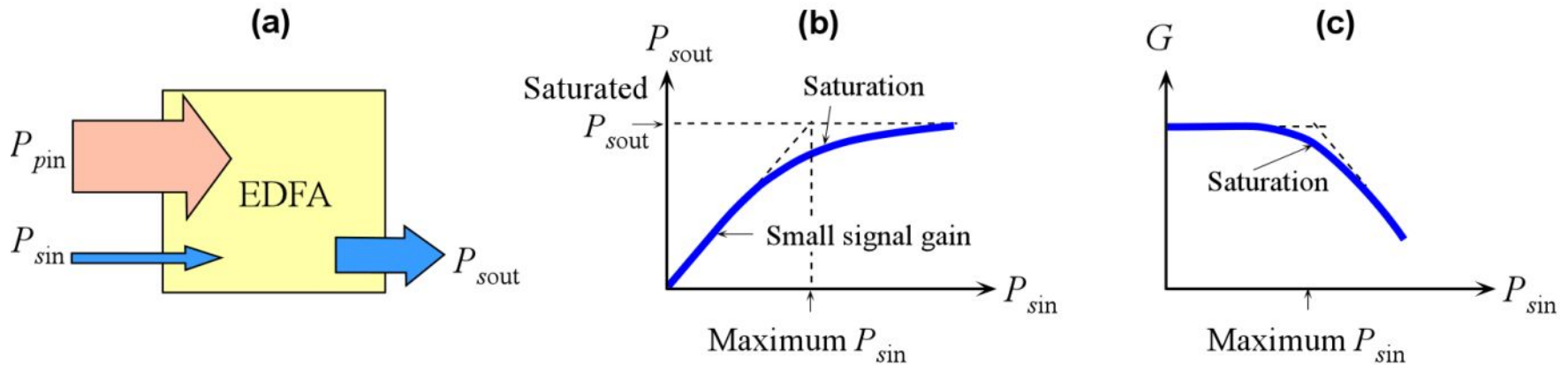

## Gain $G$

$$G = \frac{P_{sout}}{P_{sin}} = 1 + \eta_{PCE} \left( \frac{P_{pin}}{P_{sin}} \right)$$

$$P_{sin} < (\lambda_p / \lambda_s) P_{pin} / (G - 1)$$



# EDFA Pump Length

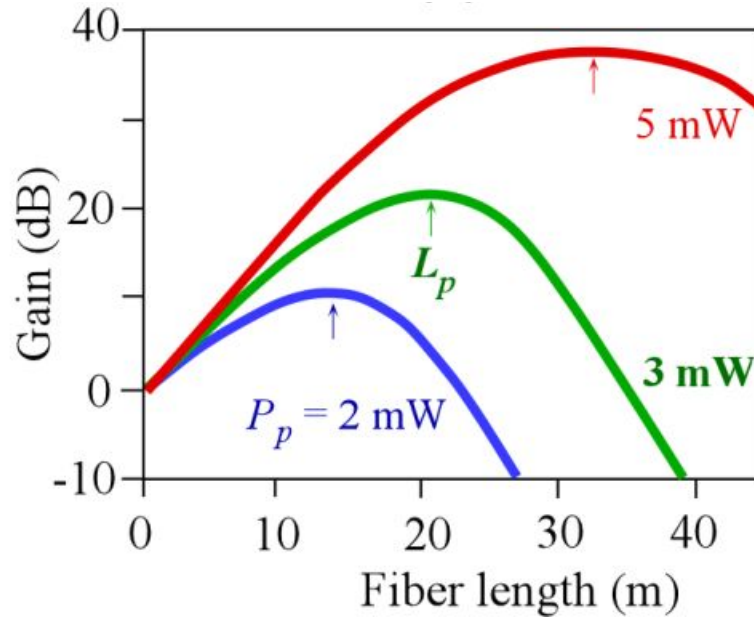

$$P_p \approx AN_0 h\nu L_p / \tau_{sp}$$

Confinement  
factor

$$\Gamma P_p \approx AN h\nu L_p / \tau_{sp}$$

$$g = \sigma_{em} N_2 - \sigma_{ab} N_1 \quad G = \exp(gL)$$





## EXAMPLE: An erbium doped fiber amplifier

Consider a 3 m EDFA that has a core diameter of  $5\ \mu\text{m}$ ,  $\text{Er}^{3+}$  doping concentration of  $1 \times 10^{19}\ \text{cm}^{-3}$  and  $\tau_{\text{sp}}$  (the spontaneous decay time from  $E_2$  to  $E_1$ ) is 10 ms. The fiber is pumped at 980 nm from a laser diode. The pump power coupled into the EDFA fiber is 25 mW. Assuming that the confinement factor  $\Gamma$  is 70%, what is the fiber length that will absorb the pump radiation? Find the small signal gain at 1550 nm for two cases corresponding to full population inversion and 90% inversion.



## EXAMPLE: An erbium doped fiber amplifier

Consider a 3 m EDFA that has a core diameter of 5  $\mu\text{m}$ ,  $\text{Er}^{3+}$  doping concentration of  $1 \times 10^{19} \text{ cm}^{-3}$  and  $\tau_{\text{sp}}$  (the spontaneous decay time from  $E_2$  to  $E_1$ ) is 10 ms. The fiber is pumped at 980 nm from a laser diode. The pump power coupled into the EDFA fiber is 25 mW. Assuming that the confinement factor  $\Gamma$  is 70%, what is the fiber length that will absorb the pump radiation? Find the small signal gain at 1550 nm for two cases corresponding to full population inversion and 90% inversion.

### Solution

The pump photon energy  $h\nu = hc/\lambda = (6.626 \times 10^{-34})(3 \times 10^8)/(980 \times 10^{-9}) = 2.03 \times 10^{-19} \text{ J}$  (or 1.27 eV)

Rearranging Eq. (4.3.6), we get

$$L_p \approx \Gamma P_p \tau_{\text{sp}} / ANh\nu_p$$

*i.e.*

$$L_p \approx (0.70)(25 \times 10^{-3} \text{ W})(10 \times 10^{-3} \text{ s}) / [\pi(2.5 \times 10^{-4} \text{ cm})^2(1 \times 10^{19} \text{ cm}^{-3})(2.03 \times 10^{-19} \text{ J})] = \mathbf{4.4 \text{ m}}$$

which is the maximum allowed length. The small signal gain can be rewritten as

$$g = \sigma_{\text{em}} N_2 - \sigma_{\text{ab}} N_1 = [\sigma_{\text{em}} (N_2/N_0) - \sigma_{\text{ab}} (N_1/N_0)] N_0$$

where  $N_1 + N_2 = N_0$  is the total  $\text{Er}^{3+}$  concentration. Let  $x = N_2/N_0$ , then  $1 - x = N_1/N_0$  where  $x$  represents the extent of pumping from 0 to 1, 1 being 100%.



## Solution (continued)

Thus, the above equation becomes

$$g = [\sigma_{em}x - \sigma_{ab}(1-x)]N_0$$

For 100% pumping,  $x = 1$ ,

$$g = [(3.2 \times 10^{-21} \text{ cm}^2)(1) - 0](1 \times 10^{19} \text{ cm}^{-3}) = 3.2 \text{ m}^{-1}$$

and

$$G = \exp(gL) = \exp[(3.2 \text{ m}^{-1})(3\text{m})] = 14,765 \text{ or } \mathbf{41.7 \text{ dB}}$$

For  $x = 0.9$  (90% pumping), we have

$$\begin{aligned} g &= [(3.2 \times 10^{-21} \text{ cm}^2)(0.9) - (2.4 \times 10^{-21} \text{ cm}^2)(0.1)](1 \times 10^{19} \text{ cm}^{-3}) \\ &= 2.64 \text{ m}^{-1} \end{aligned}$$

and

$$G = \exp(gL) = \exp[(2.64 \text{ m}^{-1})(3\text{m})] = 2,751 \text{ or } \mathbf{34.4 \text{ dB}}$$

Even at 90% pumping the gain is significantly reduced. At 70% pumping, the gain is 19.8 dB. In actual operation, it is unlikely that 100% population inversion can be achieved; 41.7 dB is a good indicator of the upper ceiling to the gain.

# EDFA Pump Equalization



(a)

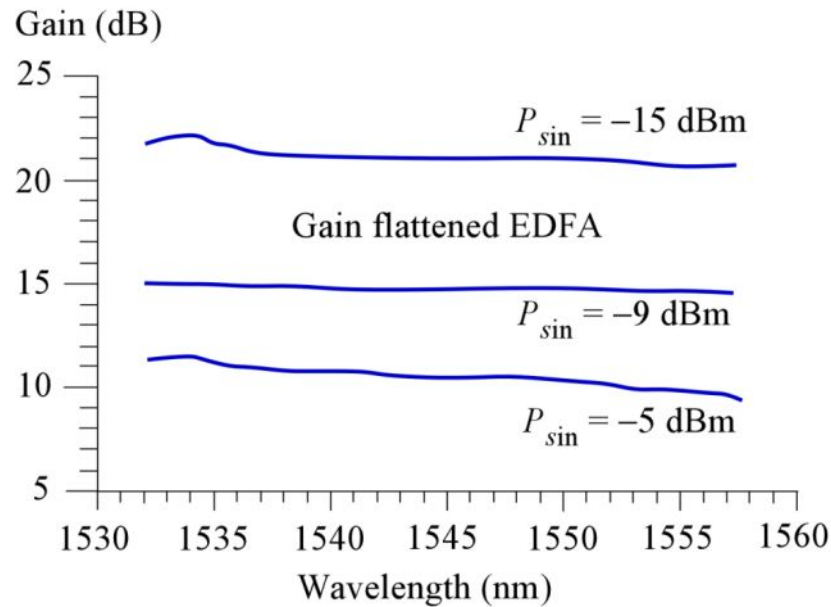

(b)

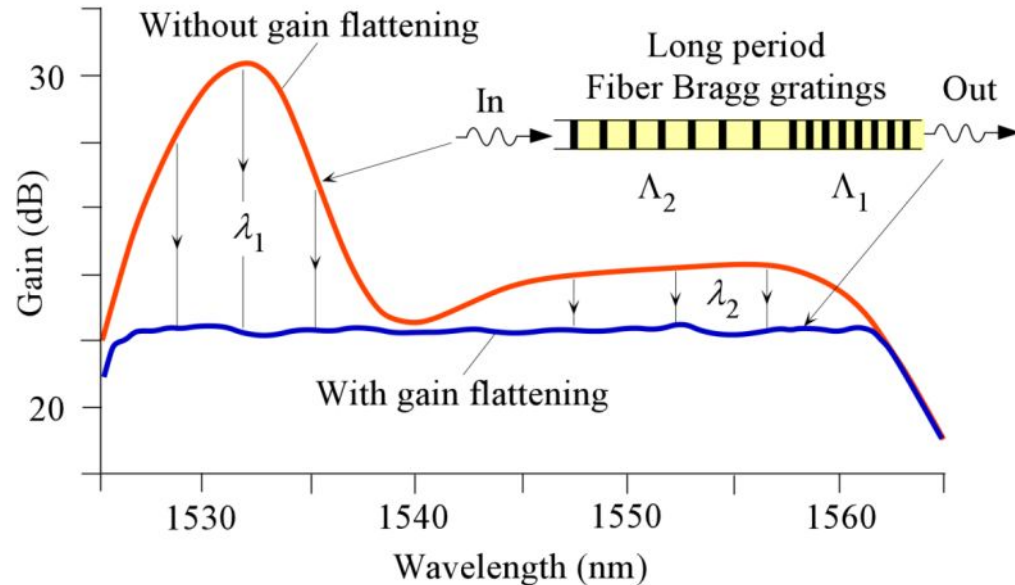

(a) The gain spectrum of one type of commercial gain flattened EDFA. The gain variation is very small over the spectrum, but the gain decreases as the input power increases due to saturation effects (Note, the corresponding power levels are 0.031, 0.13 and 0.32 mW). (b) Schematic illustration of gain equalization by using long fiber Bragg grating filters in series that attenuate the high gain regions to equalize the gain over the spectrum. (An idealized example.)

# EDFA Pump Equalization

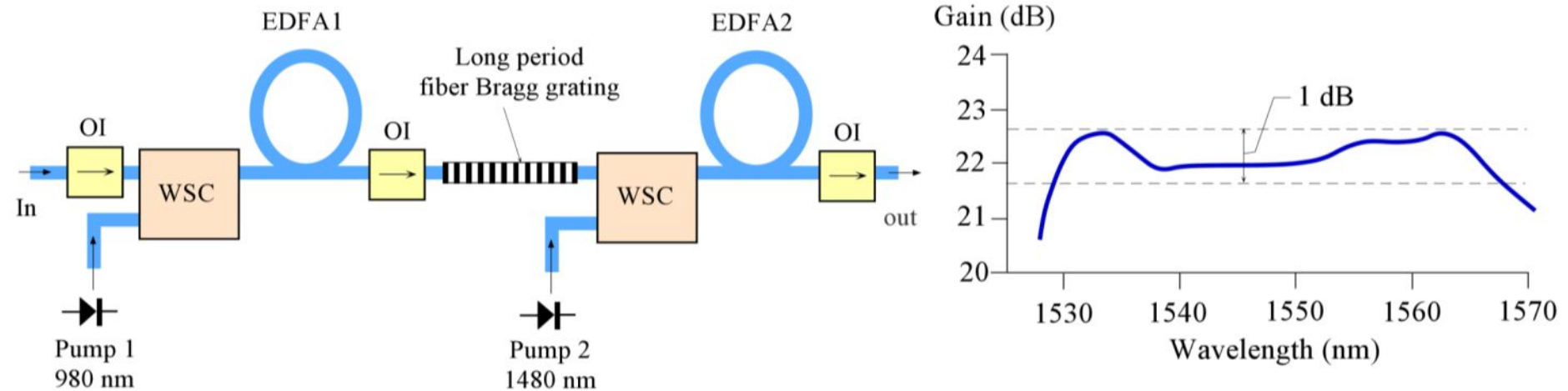

(a) A gain flattened EDFA reported by Lucent Technologies uses two EDFA and a long period grating between the two stages. (A simplified diagram). The two EDFA are pumped at 980 and 1480 nm. (b) The resulting gain spectrum for small signals is flat to better than 1 dB over a broad spectrum, 40 nm. The length of EDFA1 is 14 m, and that of EDFA2 is 15 m. Pump 1 (980 nm) and 2 (1480 nm) diodes were operated at most at power levels 76 mW and 74.5 mW respectively. EDFA2 can also be pumped counter directionally.



## EDFA Noise Figure

$$NF = \frac{SNR_{in}}{SNR_{out}}$$

$$NF(\text{dB}) = 10 \log \left( \frac{SNR_{in}}{SNR_{out}} \right)$$

# EDFA Noise

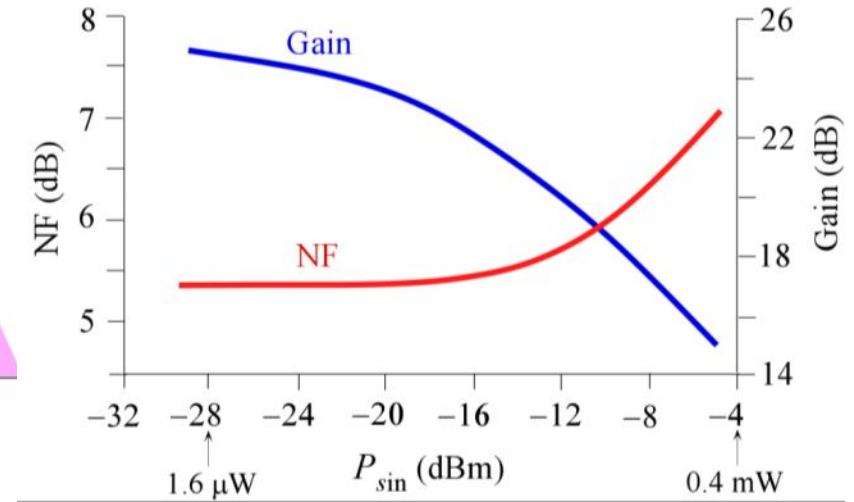
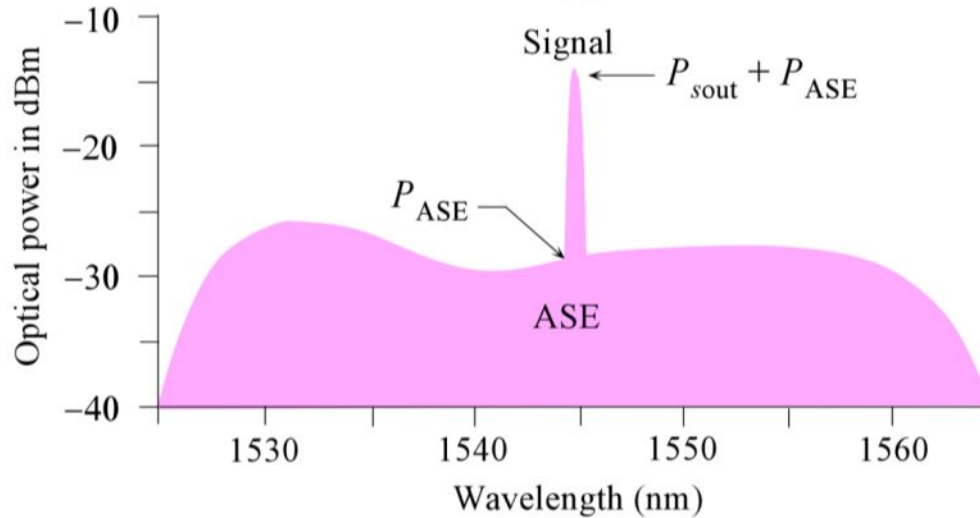

(a) Amplified spontaneous emission (ASE) noise in the output spectrum and the amplified signal. (b) The dependence of NF and gain ( $G$ ) on the input signal power level ( $P_{sin}$ ) for an EDFA under forward (codirectional) pumping. Data for the plots were selectively extracted from G.R. Walker *et al*, *J. Light Wave Technol*, 9, 182, 1991.



# He-Ne LASER

Flat mirror (Reflectivity = 0.999)      Concave mirror (Reflectivity = 0.985)

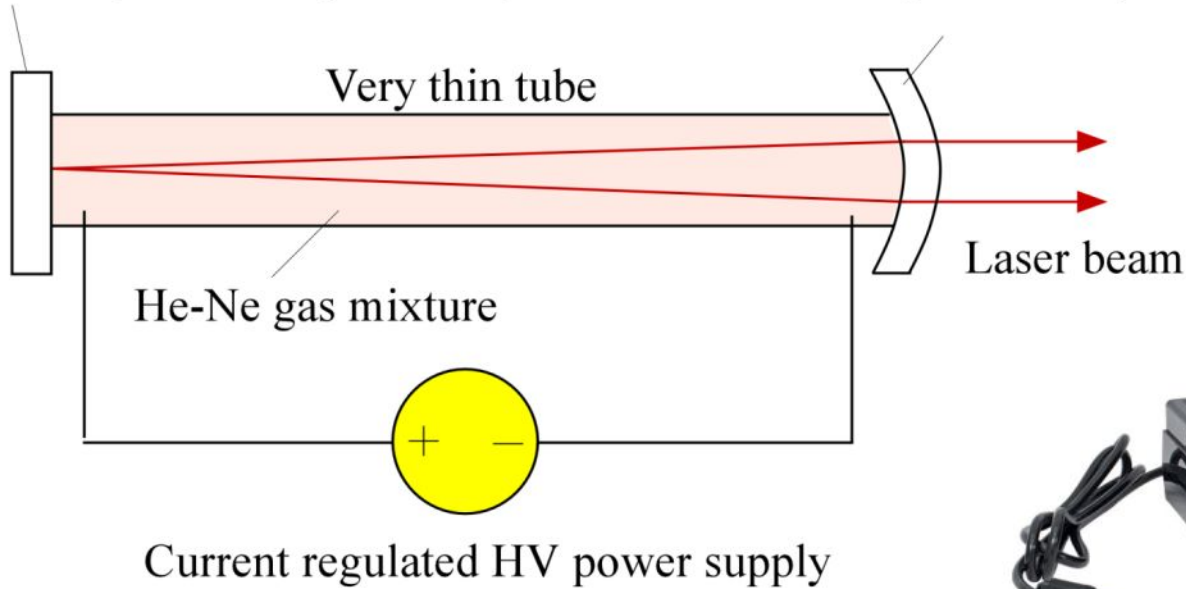



# He-Ne LASER



Ali Javan and his associates William Bennett Jr. and Donald Herriott at Bell Labs were first to successfully demonstrate a continuous wave (CW) helium-neon laser operation (1960-1962). (Reprinted with permission from Alcatel-Lucent USA Inc)

# He-Ne LASER: PRINCIPLES

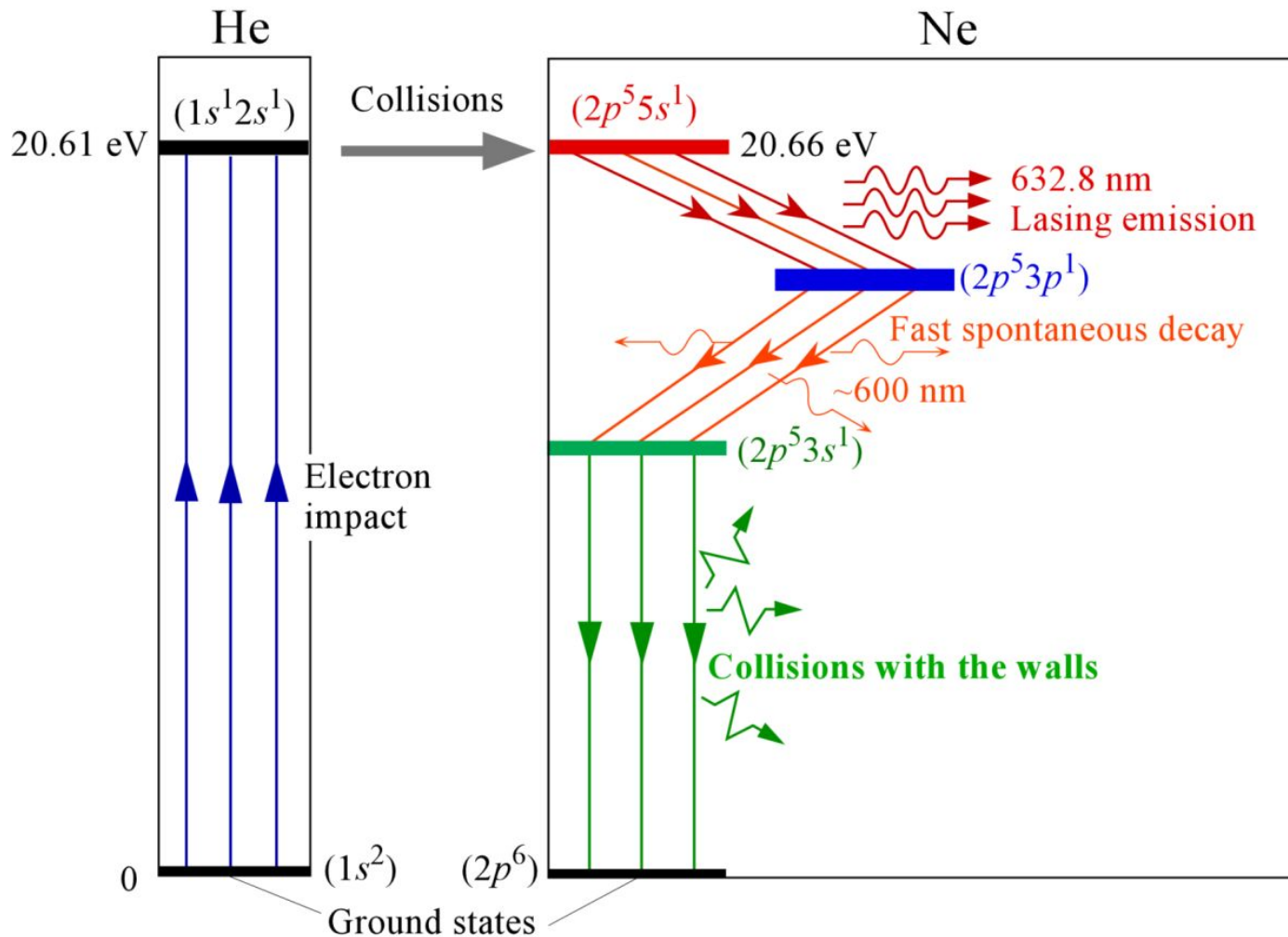

# He-Ne LASER: MODES

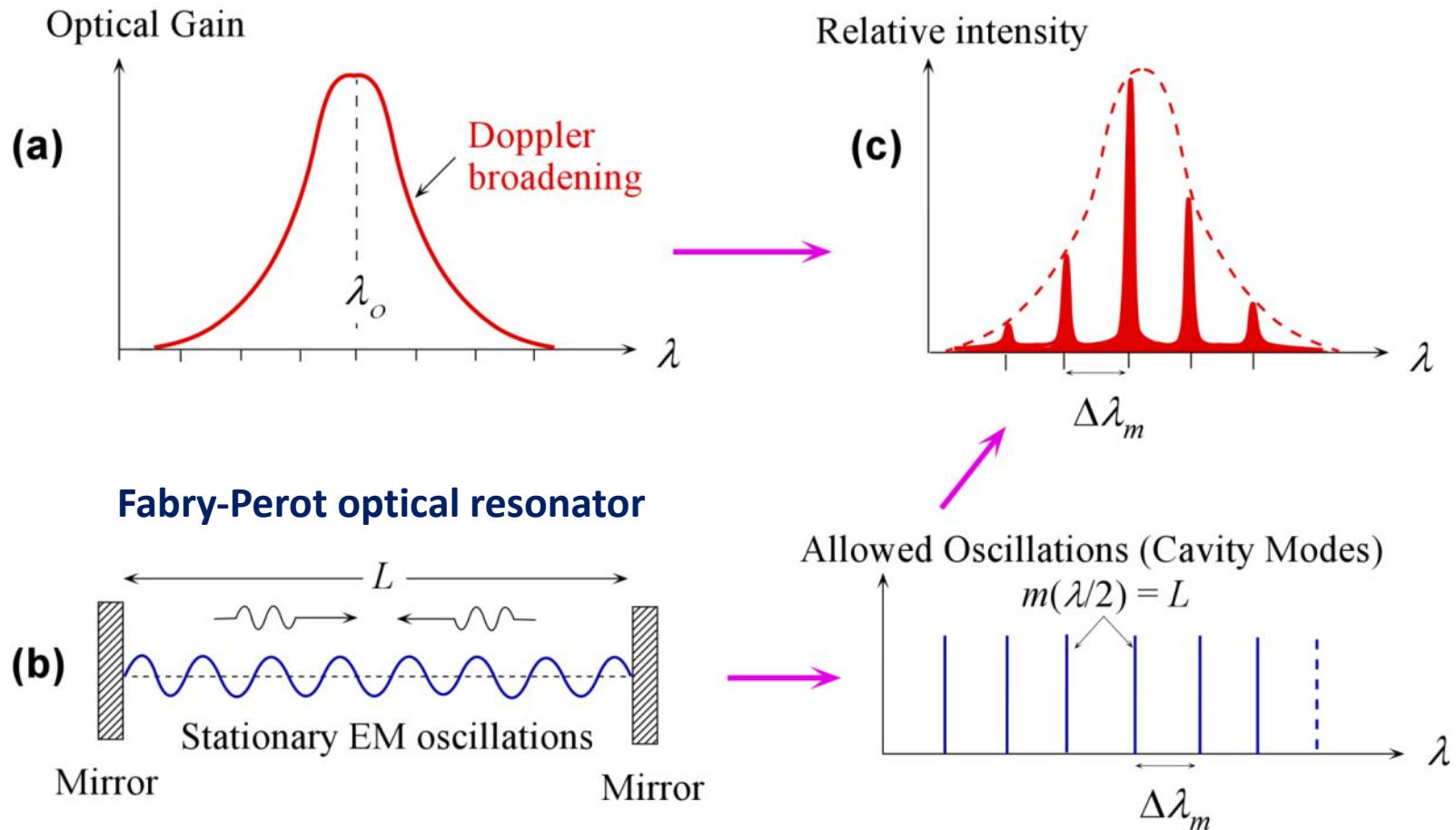

- (a) Optical gain vs. wavelength characteristics (called the optical gain curve) of the lasing medium.
- (b) Allowed modes and their wavelengths due to stationary EM waves within the optical cavity. (c) The output spectrum (relative intensity vs. wavelength) is determined by satisfying (a) and (b) simultaneously, assuming no cavity losses

# He-Ne LASER: MODES



$$\Delta\nu_{1/2} = 2\nu_o \sqrt{\frac{2k_B T \ln(2)}{Mc^2}}$$

$$\Delta\lambda_{1/2} \approx \Delta\nu_{1/2} (\lambda/\nu)$$

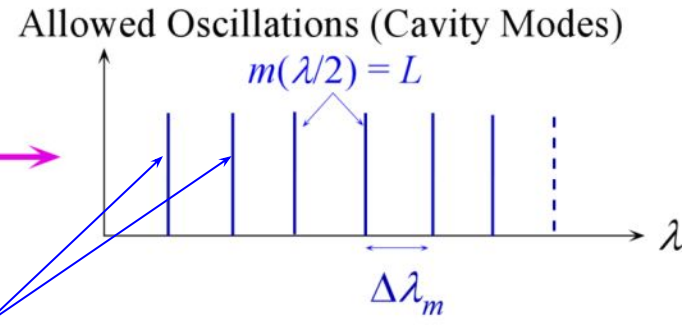
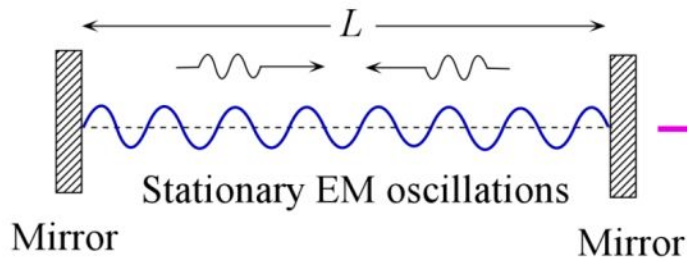
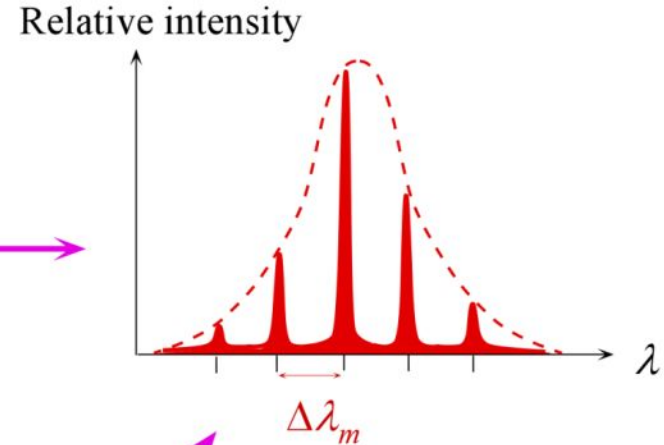
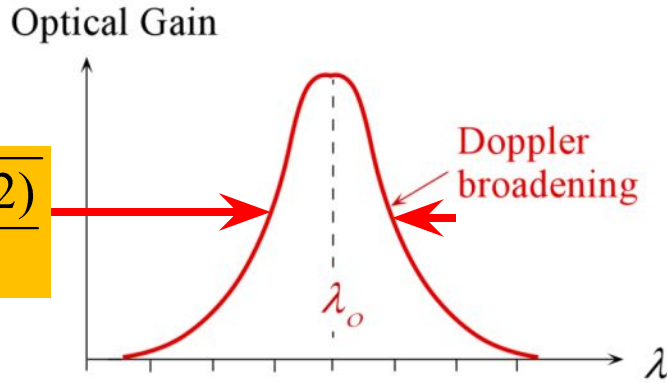

**Axial or longitudinal modes**

$$m \left( \frac{\lambda}{2} \right) = L$$

**Longitudinal mode number**

# He-Ne LASER: Number of Modes

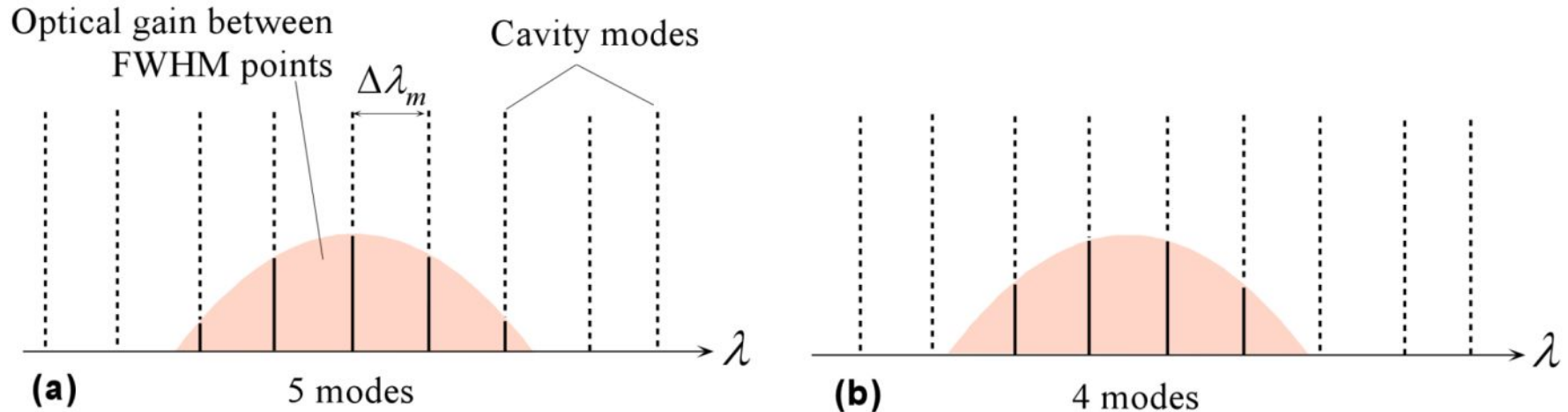

Number of laser modes depends on how the cavity modes intersect the optical gain curve. In this case we are looking at modes within the linewidth  $\Delta\lambda_{1/2}$ .



# He-Ne LASER

## What are other lasing emissions?

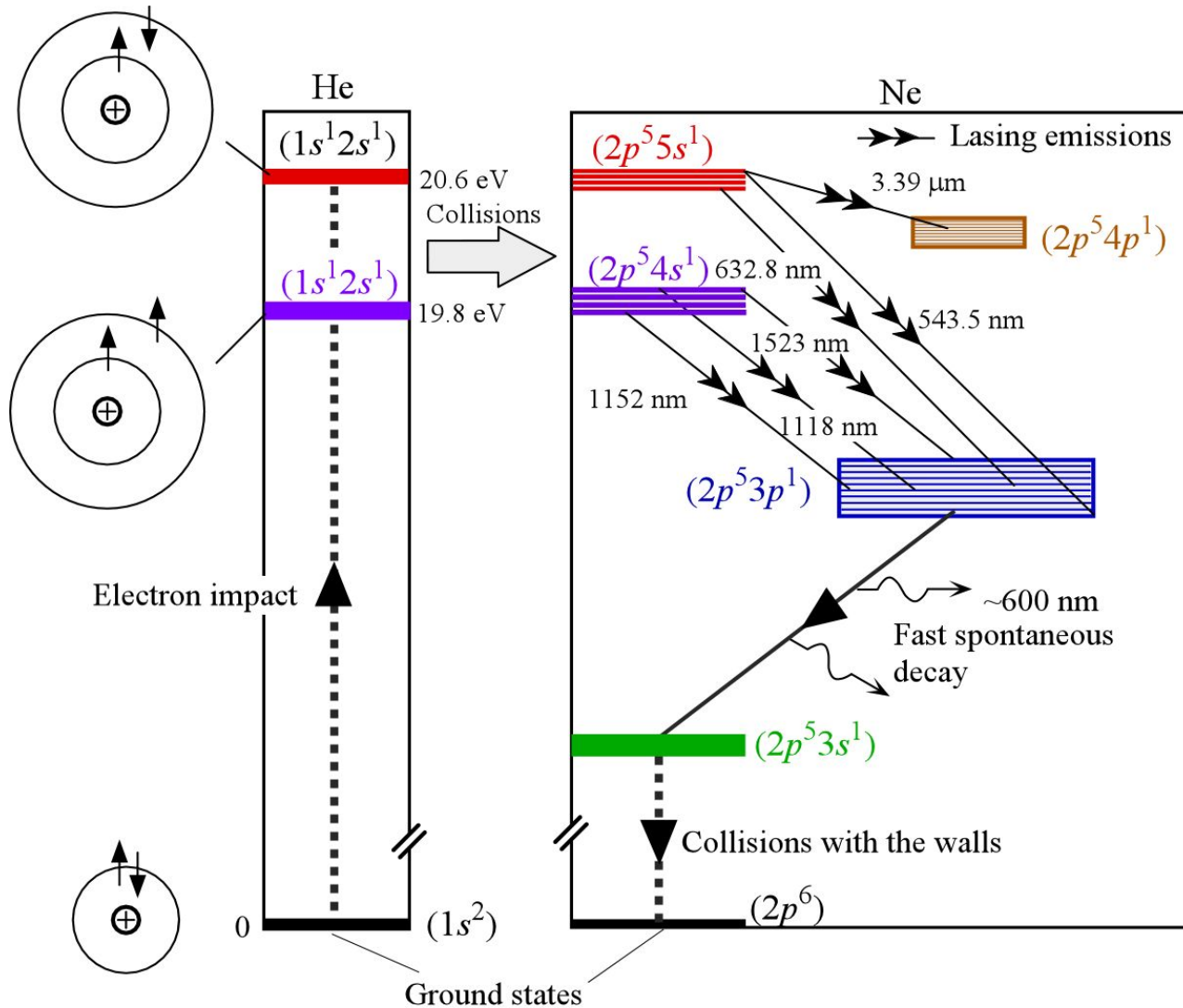



# What are other lasing emissions?

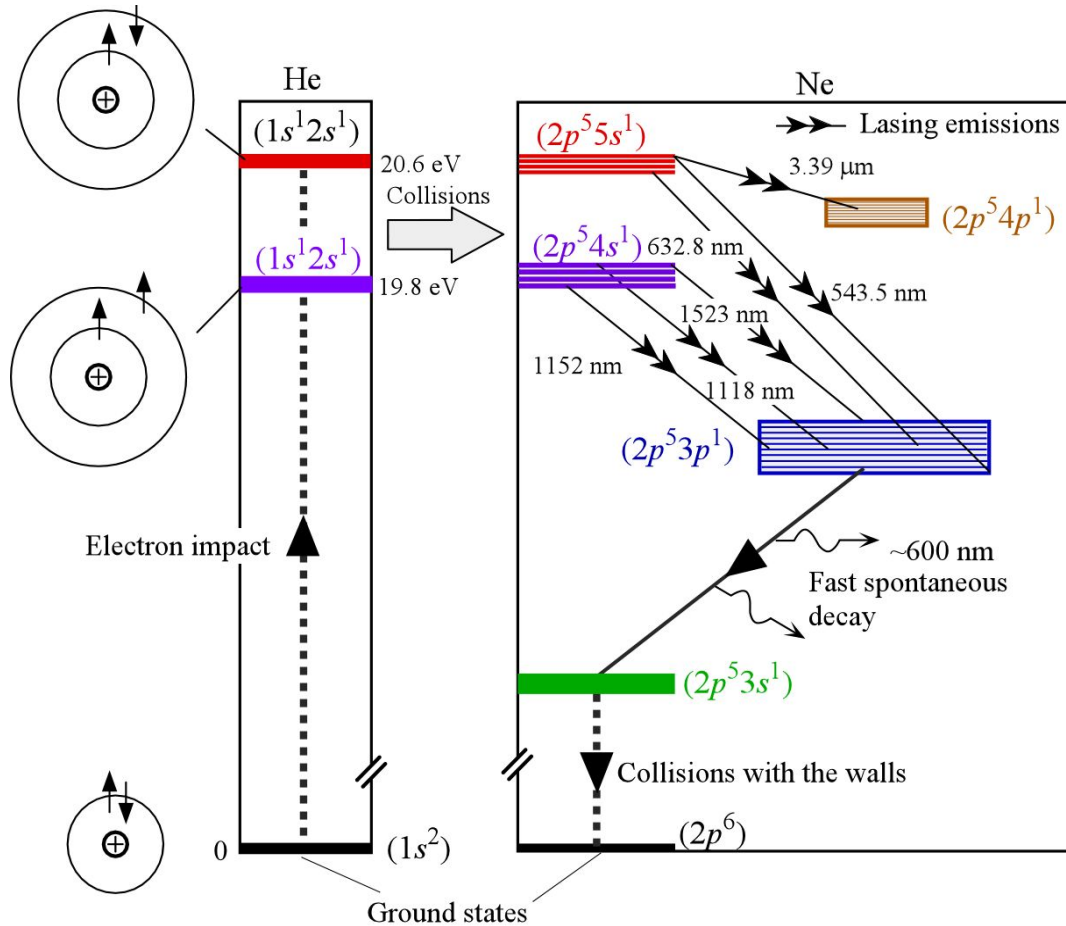

Wavelength (nm)	543.5	594.1	612	632.8	1523
Color	Green	Yellow	Orange	Red	Infrared



### **EXAMPLE: Efficiency of the He-Ne laser**

A typical low-power 5mW He-Ne laser tube operates at a dc voltage of 2000 V and carries a current of 7 mA. What is the efficiency of the laser ?





### EXAMPLE: Efficiency of the He-Ne laser

A typical low-power 5mW He-Ne laser tube operates at a dc voltage of 2000 V and carries a current of 7 mA. What is the efficiency of the laser ?

## Solution

From the definition of efficiency,

$$\begin{aligned}\text{Efficiency} &= \frac{\text{Output Light Power}}{\text{Input Electrical Power}} = \frac{5 \times 10^{-3} \text{ W}}{(7 \times 10^{-3} \text{ A})(2000 \text{ V})} \\ &= 0.036\%\end{aligned}$$

Typically He-Ne efficiencies are less than 0.1%. What is important is the highly coherent output radiation. Note that 5 mW over a beam diameter of 1 mm is 6.4 kW m<sup>-2</sup>.

# EXAMPLE: He-Ne laser Doppler broadened linewidth



Calculate the Doppler broadened linewidths  $\Delta\nu$  and  $\Delta\lambda$  (end-to-end of spectrum) for the He-Ne laser transition for  $\lambda_o = 632.8$  nm if the gas discharge temperature is about  $127^\circ\text{C}$ . The atomic mass of Ne is  $20.2$  ( $\text{g mol}^{-1}$ ). The laser tube length is  $40$  cm. What is the linewidth in the output wavelength spectrum? What is mode number  $m$  of the central wavelength, the separation between two consecutive modes and how many modes do you expect within the linewidth  $\Delta\lambda_{1/2}$  of the optical gain curve?



## Solution

Due to the Doppler effect arising from the random motions of the gas atoms, the laser radiation from gas-lasers is broadened around a central frequency  $\nu_o$ . The central  $\nu_o$  corresponds to the source frequency. Higher frequencies detected will be due to radiations emitted from atoms moving toward the observer whereas lower frequency will be result of the emissions from atoms moving away from the observer. We will first calculate the frequency width using two approaches, one approximate and the other more accurate. Suppose that  $v_x$  is the root-mean-square (rms) velocity along the x-direction. We can intuitively expect the frequency width  $\Delta\nu_{\text{rms}}$  between rms points of the Gaussian output frequency spectrum to be

$$\Delta\nu_{\text{rms}} = \nu_o \left( 1 + \frac{v_x}{c} \right) - \nu_o \left( 1 - \frac{v_x}{c} \right) = \frac{2\nu_o v_x}{c} \quad (4.5.5)$$

## EXAMPLE: Doppler broadened linewidth



### Solution (continued)

We need to know the rms velocity  $v_x$  along x which is given by the kinetic molecular theory as  $\frac{1}{2}M v_x^2 = \frac{1}{2}k_B T$ , where  $M$  is the mass of the atom. We can therefore calculate  $v_x$ . For the He-Ne laser, it is the Ne atoms that lase, so  $M = (20.2 \times 10^{-3} \text{ kg mol}^{-1}) / (6.02 \times 10^{23} \text{ mol}^{-1}) = 3.35 \cdot 10^{-26} \text{ kg}$ . Thus,

$$\begin{aligned} v_x &= [(1.38 \times 10^{-23} \text{ J K}^{-1})(127+273\text{K}) / (3.35 \times 10^{-26} \text{ kg})]^{1/2} \\ &= 405.9 \text{ m s}^{-1} \end{aligned}$$

The central frequency is

$v_o = c/\lambda_o = (3 \times 10^8 \text{ m s}^{-1}) / (632.8 \times 10^{-9} \text{ m}) = 4.74 \times 10^{14} \text{ s}^{-1}$  The rms frequency linewidth is approximately,

$$\begin{aligned} \Delta v_{\text{rms}} &\approx (2v_o v_x) / c \\ &= 2(4.74 \times 10^{14} \text{ s}^{-1})(405.9 \text{ m s}^{-1}) / (3 \times 10^8 \text{ m s}^{-1}) \\ &= 1.28 \text{ GHz}. \end{aligned}$$

The FWHM width  $\Delta v_{1/2}$  of the output frequency spectrum will be given by Eq. (4.4.3)

$$\begin{aligned} \Delta v_{1/2} &= 2v_o \sqrt{\frac{2k_B T \ln(2)}{Mc^2}} = 2(4.74 \times 10^{14}) \sqrt{\frac{2(1.38 \times 10^{-23})(400) \ln(2)}{(3.35 \times 10^{-26})(3 \times 10^8)^2}} \\ &= 1.51 \text{ GHz}, \end{aligned}$$

which is about 18% wider than the estimate from Eq. (4.5.5).

## EXAMPLE: Doppler broadened linewidth



### Solution (continued)

To get FWHM wavelength width  $\Delta\lambda_{1/2}$ , differentiate  $\lambda = c/v$

$$\frac{d\lambda}{dv} = -\frac{c}{v^2} \lambda$$

so that

$$\Delta\lambda_{1/2} \approx \Delta v_{1/2} \left| -\lambda/v \right| = (1.51 \times 10^9 \text{ Hz})(632.8 \times 10^{-9} \text{ m}) / (4.74 \times 10^{14} \text{ s}^{-1})$$

or

$$\Delta\lambda_{1/2} \approx 2.02 \cdot 10^{-12} \text{ m, or } 2.02 \text{ pm.}$$

This width is between the half-points of the spectrum. The rms linewidth would be 0.0017 nm. Each mode in the cavity satisfies  $m(\lambda/2) = L$  and since  $L$  is some  $4.7 \times 10^5$  times greater than  $\lambda$ , the mode number  $m$  must be very large. For  $\lambda = \lambda_o = 632.8$  nm, the corresponding mode number  $m_o$  is,

$$m_o = 2L / \lambda_o = (2 \times 0.4 \text{ m}) / (632.8 \times 10^{-9} \text{ m}) = 1.264,222.5$$

and actual  $m_o$  has to be the closest integer value, that is, 1.264,222 or 1.264,223

## EXAMPLE: Doppler broadened linewidth



### Solution (continued)

The separation  $\Delta\lambda_m$  between two consecutive modes ( $m$  and  $m + 1$ ) is

$$\Delta\lambda_m = \lambda_m - \lambda_{m+1} = \frac{2L}{m} - \frac{2L}{m+1} \approx \frac{2L}{m^2}$$

or

$$\Delta\lambda_m \text{ Separation between modes} = \frac{\lambda_0^2}{2L} \quad (4.5.7)$$

Substituting the values, we find  $\Delta\lambda_m = (632.8 \times 10^{-9})^2 / (2 \times 0.4) = 5.01 \times 10^{-13}$  m or 0.501 pm.

We can also find the separation of the modes by noting that Eq. (4.5.4), in which  $\lambda = c/v$ , is equivalent to

$$v = mc/2L \quad \text{Frequency of a mode} \quad (4.5.8)$$

so that the separation of modes in frequency,  $\Delta v_m$ , is simply

$$\Delta v_m = c/2L \quad \text{Frequency separation of modes} \quad (4.5.9)$$

Substituting  $L = 0.40$  m in Eq. (4.5.9), we find  $\Delta v_m = 375$  MHz. (A typical value for a He-Ne laser.)

## EXAMPLE: Doppler broadened linewidth



### Solution (continued)

The number of modes, *i.e.* the number of  $m$  values, within the linewidth, that is, between the half-intensity points will depend on how the cavity modes and the optical gain curve coincide, for example, whether there is a cavity mode right at the peak of the optical gain curve as illustrated in Figure 4.20 . Suppose that we try to estimate the number of modes by using,

$$\text{Modes} \approx \frac{\text{Linewidth of spectrum}}{\text{Separation of two modes}} \approx \frac{\Delta\lambda_{1/2}}{\Delta\lambda_m} = \frac{2.02 \text{ pm}}{0.501 \text{ pm}} = 4.03$$

We can expect at most 4 to 5 modes within the linewidth of the output as shown in Figure 4.20. We neglected the cavity losses.

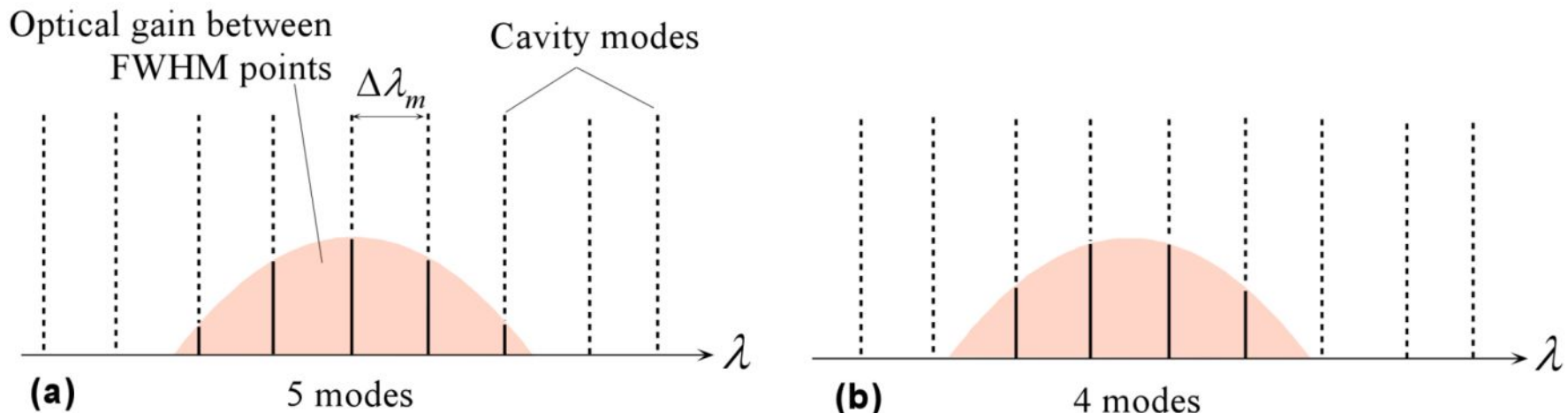



# Argon-Ion Laser

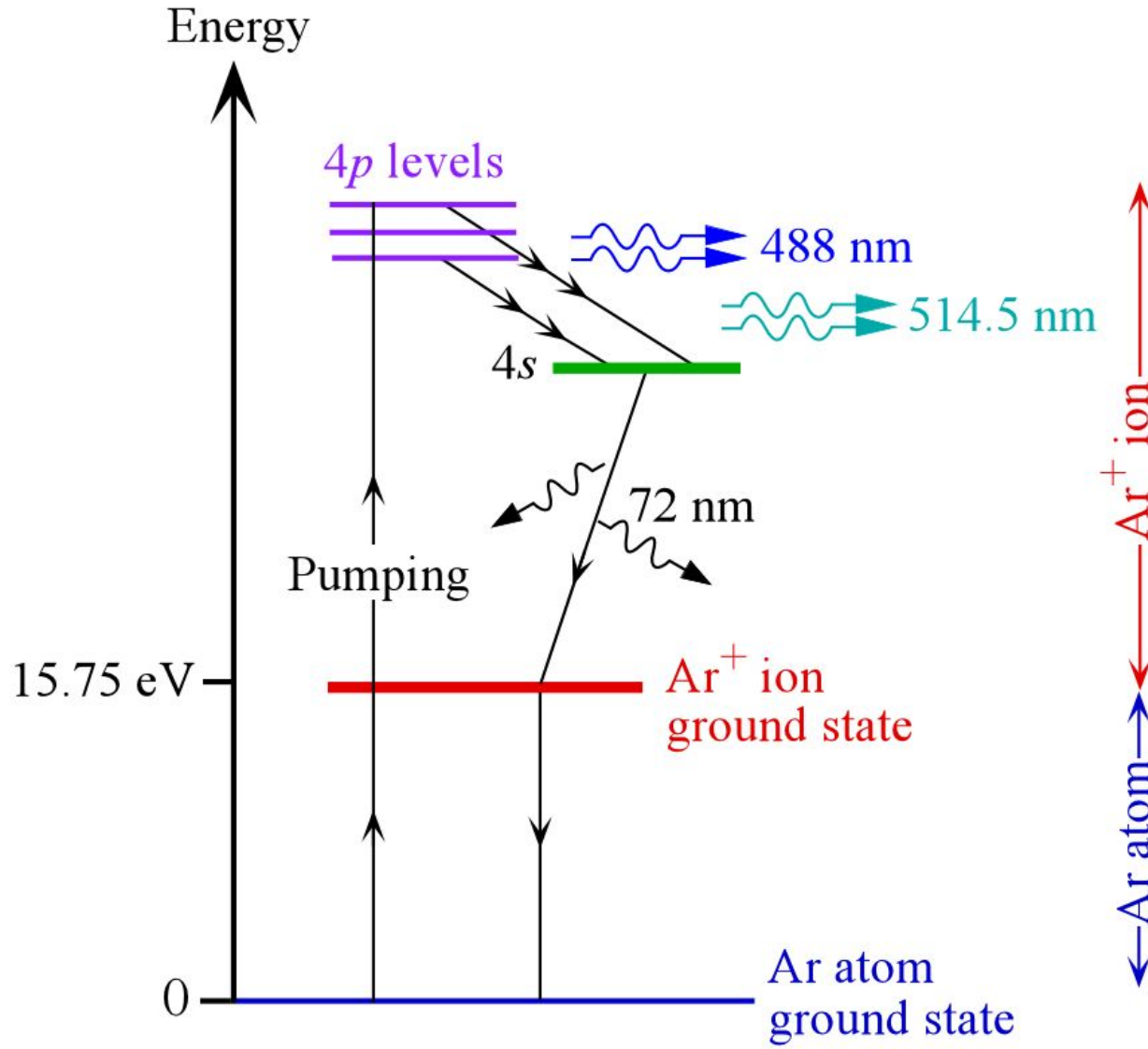



# Argon-Ion Laser



The Ar atoms are ionized by electron collisions in a high current electrical discharge.

Multiple collisions with electrons excite the argon ion,  $\text{Ar}^+$ , to a group of  $4p$  energy levels  $\sim 35$  eV above the atomic ground.

A population inversion forms between the  $4p$  levels and the  $4s$  level which is about 33.5 eV above the Ar atom ground level.

The stimulated radiation from the  $4p$  levels down to the  $4s$  level contains a series of wavelengths ranging from 351.1 nm to 528.7 nm. Most of the power however is concentrated, approximately equally, in the 488 and 514.5 nm emissions.

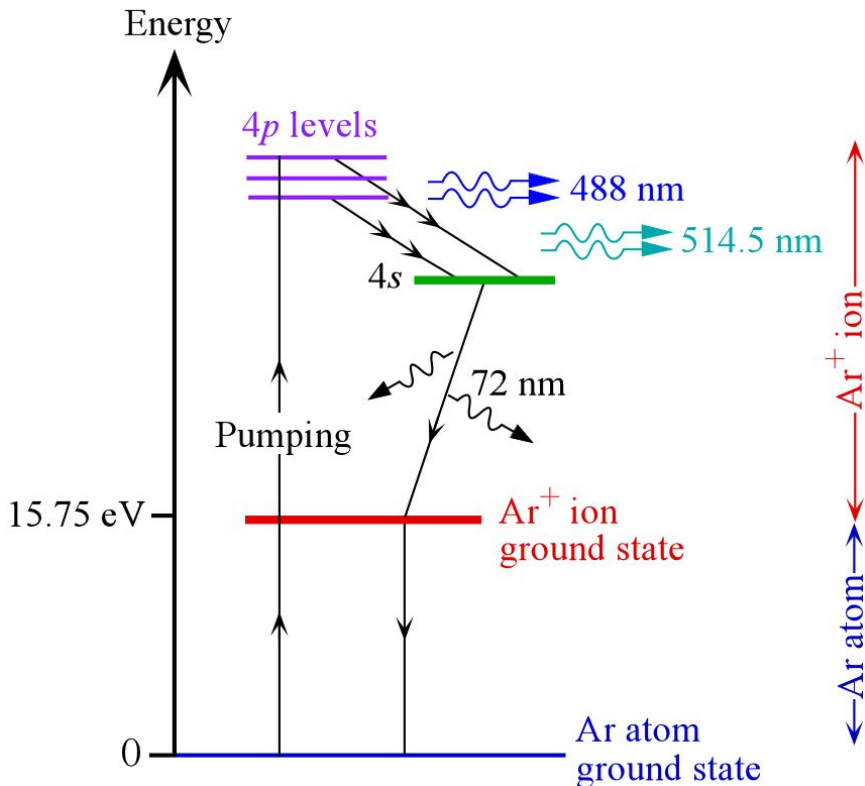

The  $\text{Ar}^+$  ion at the lower laser level ( $4s$ ) returns to its neutral atomic ground state via a radiative decay to the  $\text{Ar}^+$  ion ground state, followed by recombination with an electron to form the neutral atom.

The Ar atom is then ready for "pumping" again.

# Optical Gain Coefficient and Population Inversion

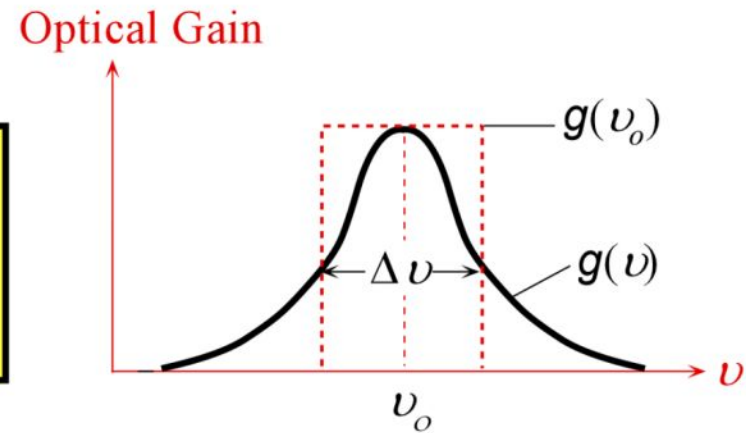
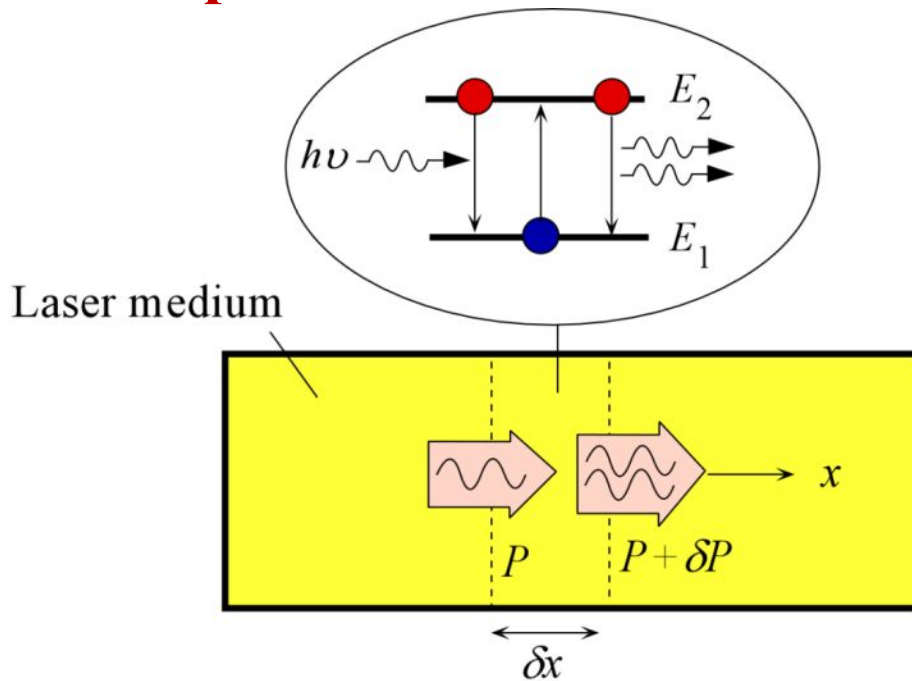

$$g = \frac{\delta P}{P \delta x} = \frac{\delta N_{\text{ph}}}{N_{\text{ph}} \delta x} = \frac{n}{c N_{\text{ph}}} \frac{\delta N_{\text{ph}}}{\delta t}$$

$$\begin{aligned} \frac{dN_{\text{ph}}}{dt} &= \text{Net rate of stimulated photon emission} \\ &= N_2 B_{21} \rho(\nu) - N_1 B_{21} \rho(\nu) = (N_2 - N_1) B_{21} \rho(\nu) \end{aligned}$$

$$g(\nu_0) \approx (N_2 - N_1) \frac{B_{21} n h \nu_0}{c \Delta \nu}$$

$$\rho(\nu_0) \approx \frac{N_{\text{ph}} h \nu_0}{\Delta \nu}$$

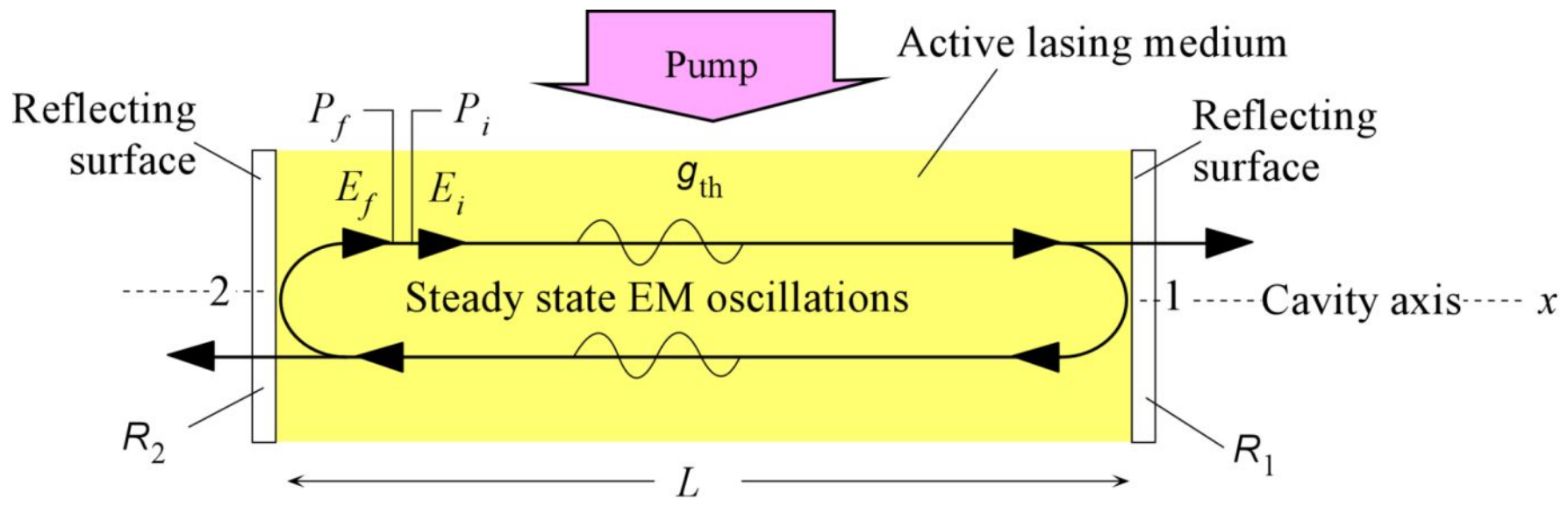

$$G_{op} = P_f / P_i = 1$$

$$P_f = P_i R_1 R_2 \exp[g(2L)] \exp[-\alpha_s(2L)]$$

$$g_{th} = \alpha_s + \frac{1}{2L} \ln \left( \frac{1}{R_1 R_2} \right) = \alpha_t$$

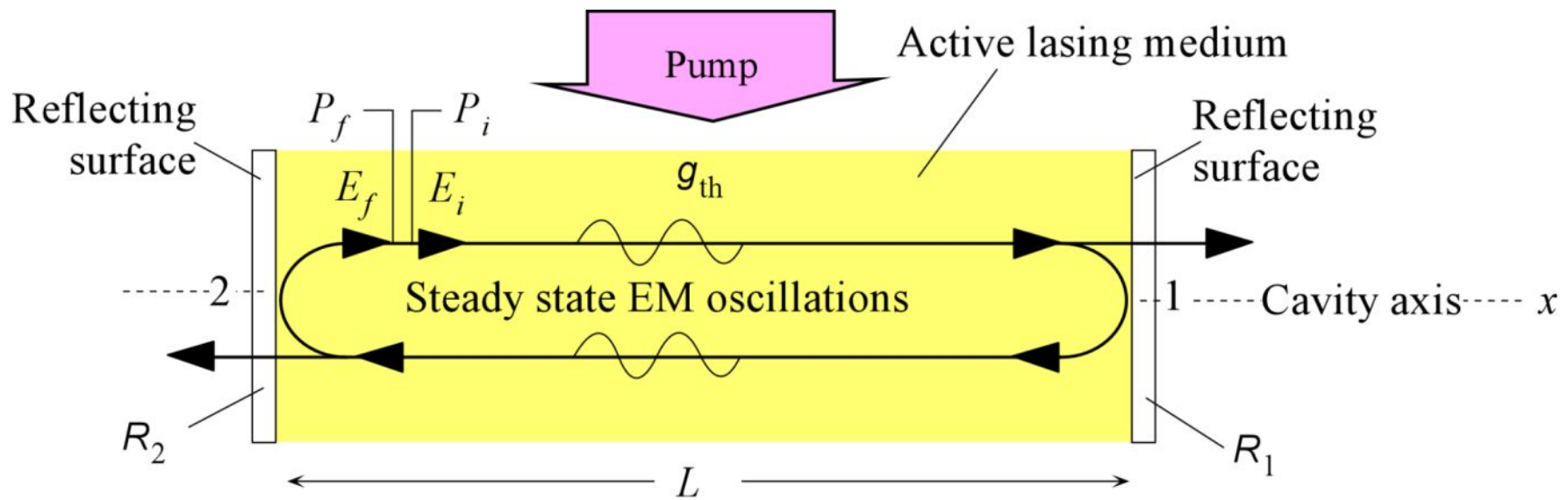

$$(N_2 - N_1)_{\text{th}} \approx g_{\text{th}} \frac{c \Delta \nu}{B_{21} n h \nu_o}$$

$$(N_2 - N_1)_{\text{th}} \approx g_{\text{th}} \frac{8 \pi n^2 \nu_o^2 \tau_{\text{sp}} \Delta \nu}{c^2}$$

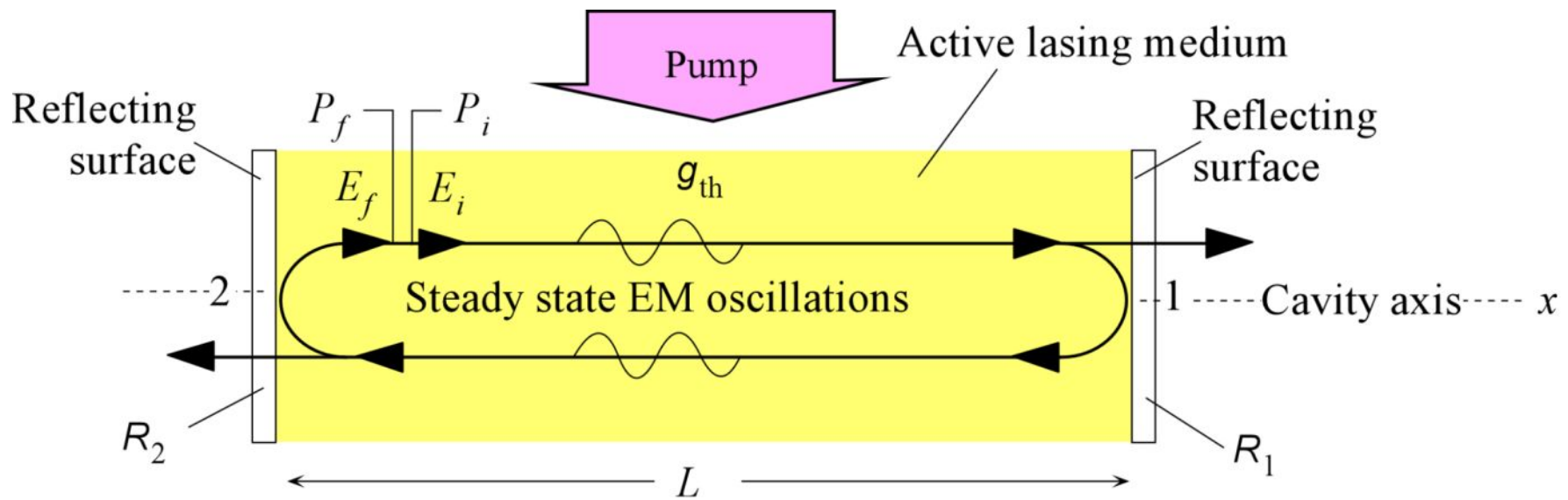

$$nk_m(2L) = m(2\pi)$$

$$m \left( \frac{\lambda_m}{2n} \right) = L$$

$$\nu_m = \frac{mc}{2nL}$$



# Laser Output vs. Pump Rate

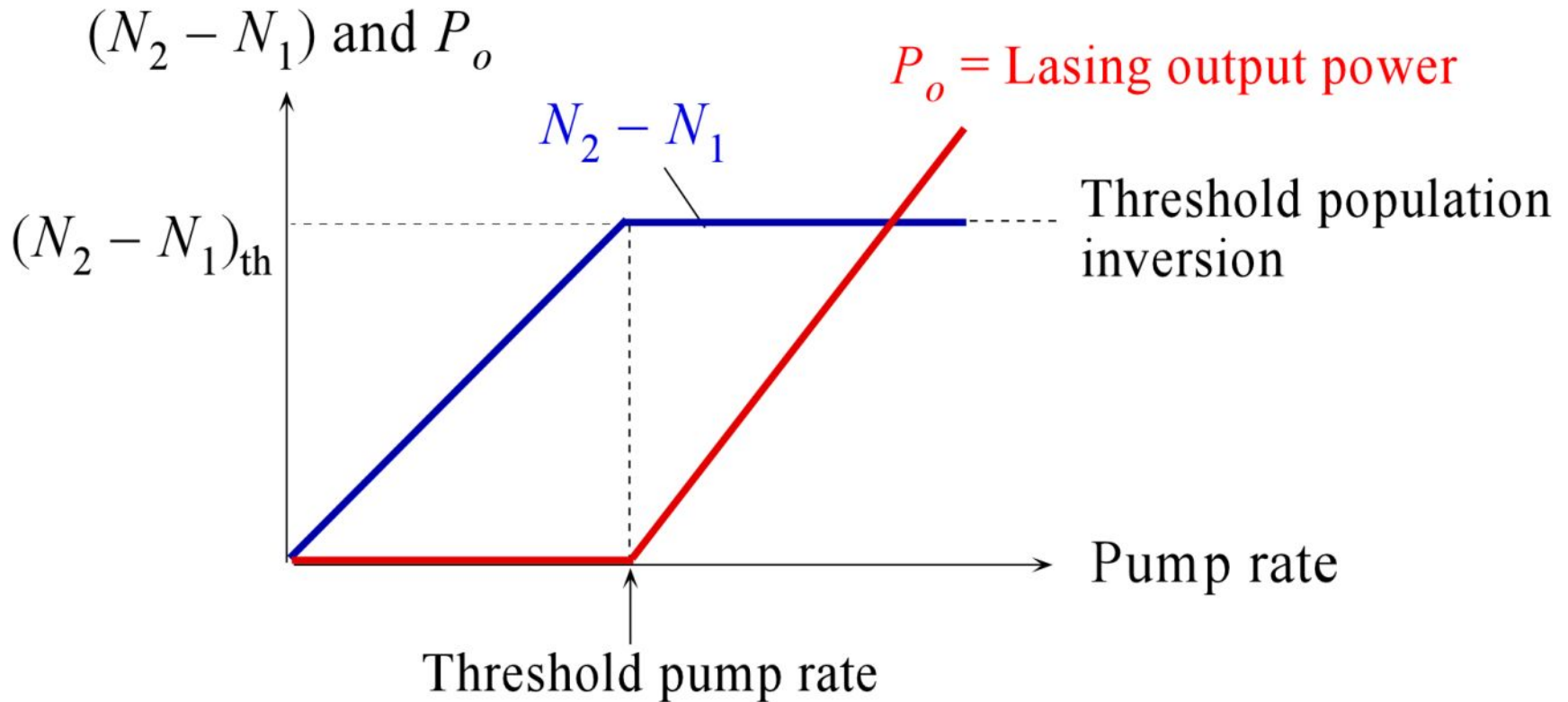

A simplified description of a laser oscillator.  $(N_2 - N_1)$  and coherent output power ( $P_o$ ) vs. pump rate under continuous wave steady state operation.



## EXAMPLE: Threshold population inversion for the He-Ne laser

Consider a He-Ne gas laser operating at the wavelength 632.8 nm (equivalent to  $\nu_o = 473.8$  THz). The tube length  $L = 40$  cm and mirror reflectances are approximately 95% and 100%. The linewidth  $\Delta\nu$  is 1.5 GHz, the loss coefficient  $\alpha_s$  is  $0.05 \text{ m}^{-1}$ , the spontaneous decay time constant  $\tau_{sp}$  is roughly 100 ns, and  $n \approx 1$ . What are the threshold gain coefficient and threshold population inversion?

### Solution

The threshold gain coefficient from Eq. (4.6.7) is

$$g_{\text{th}} = \alpha_s + \frac{1}{2L} \ln \left( \frac{1}{R_1 R_2} \right) = (0.05 \text{ m}^{-1}) + \frac{1}{2(0.4 \text{ m})} \ln \left[ \frac{0.114 \text{ m}^{-1}}{(0.95)(1)} \right]$$

The threshold population inversion from Eq. (4.6.9) is

$$\begin{aligned} \Delta N_{\text{th}} &\approx g_{\text{th}} \frac{8\pi n^2 \nu_o^2 \tau_{sp} \Delta\nu}{c^2} \\ &= (0.114 \text{ m}^{-1}) \frac{8\pi (1)^2 (473.8 \times 10^{12} \text{ s}^{-1})^2 (100 \times 10^{-9} \text{ s})(1.5 \times 10^9 \text{ s}^{-1})}{(3 \times 10^8 \text{ m s}^{-1})^2} \\ &= 1.1 \times 10^{15} \text{ m}^{-3}. \end{aligned}$$



## EXAMPLE: Threshold population inversion for the He-Ne laser

### Solution (continued)

Note that this is the threshold population inversion for Ne atoms in configurations  $2p^55s^1$  and  $2p^53p^1$ .

The spontaneous decay time  $\tau_{sp}$  is the natural decay time of Ne atoms from  $E_2$  ( $2p^55s^1$ ) to  $E_1$  ( $2p^53p^1$ ). This time must be much longer than the spontaneous decay from  $E_1$  to lower levels to allow a population inversion to be built-up between  $E_2$  and  $E_1$ , which is the case in the He-Ne laser.

Equation (4.6.8) was a simplified derivation that used two energy levels;  $E_2$  and  $E_1$ . The He-Ne case is actually more complicated because the excited Ne atom can decay from  $E_2$  not only to  $E_1$  but to other lower levels as well. While the He-Ne is lasing, the optical cavity ensures that the photon density in cavity promotes the  $E_2$  to  $E_1$  transitions to maintain the lasing operation.





# Laser Cavity

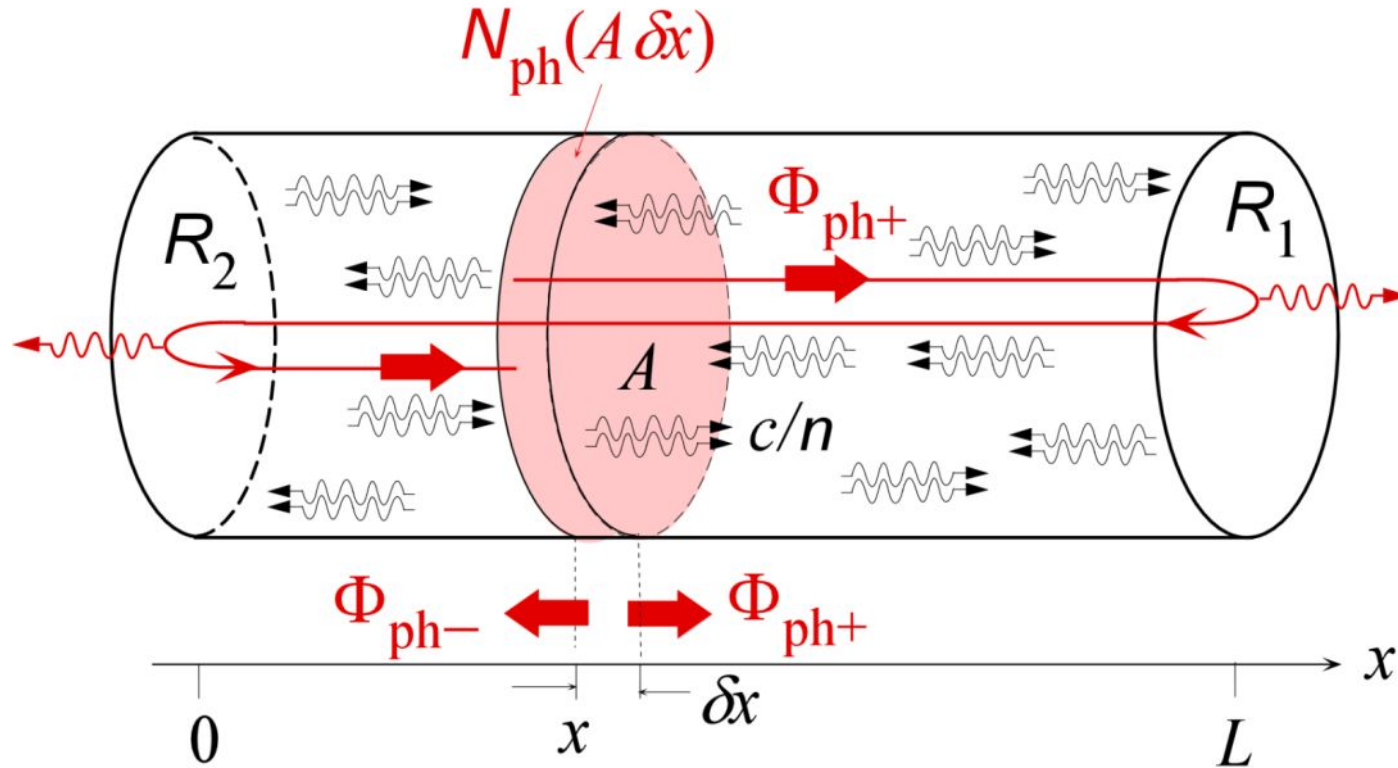

A pictorial visualization of photons inside a laser optical cavity bouncing back and forth between the cavity ends with some being transmitted.  $N_{\text{ph}}$  is the *photon concentration* inside the cavity.  $\Phi_{\text{ph}+}$  is the *photon flux* in the  $+x$  direction

$$\Phi_{\text{ph}+} = \frac{1}{2} N_{\text{ph}} (c/n)$$



# Laser Cavity

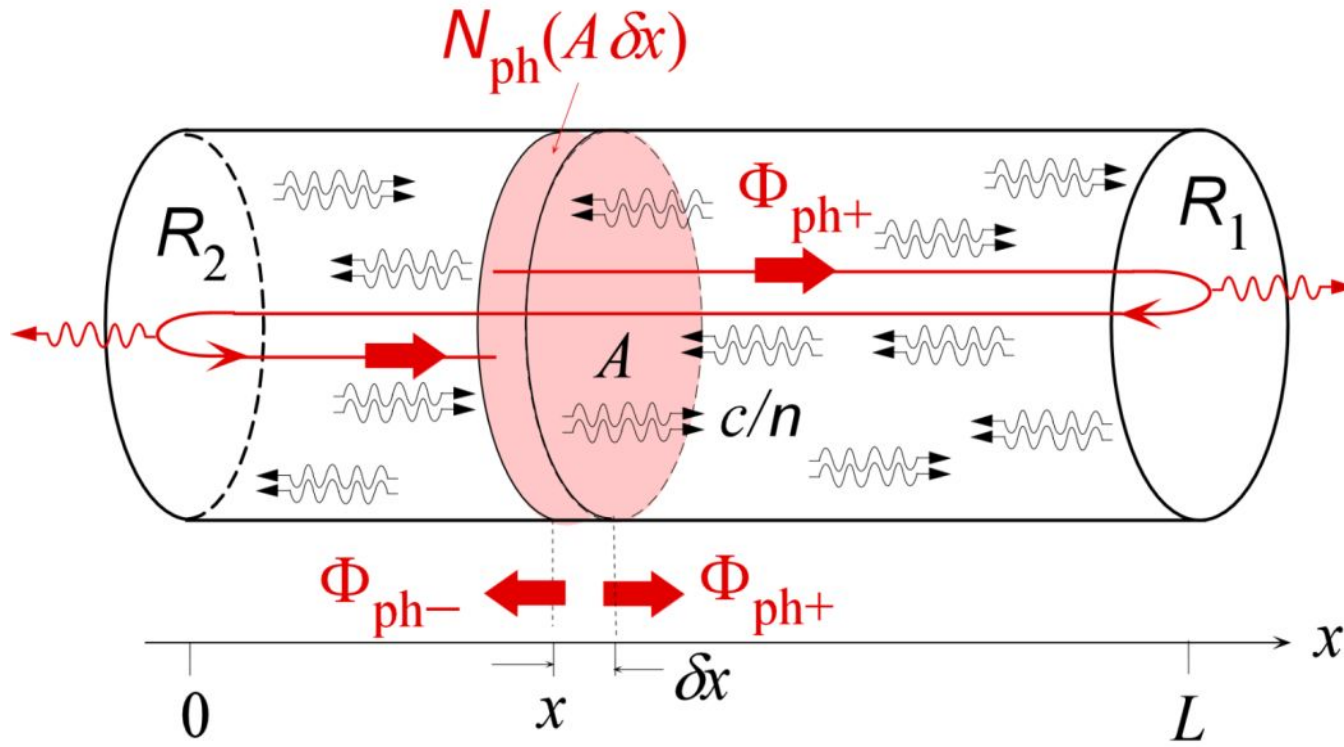

$$\Phi_{\text{ph}+} = \frac{1}{2} N_{\text{ph}} (c/n)$$

$$P_o \approx \frac{1}{2} A (1 - R_1) h \nu_o N_{\text{ph}} c/n$$



# Photon Cavity Lifetime

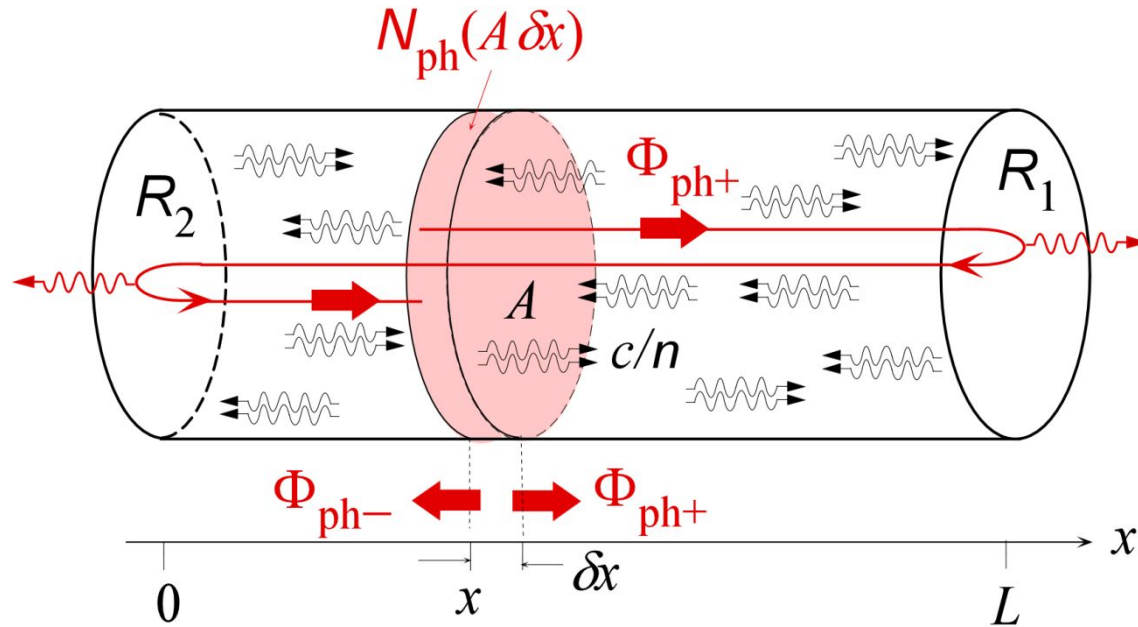

$$\delta\Phi_{\text{ph}+} = -\Phi_{\text{ph}} [1 - \exp(-2\alpha_t L)]$$

$$\tau_{\text{ph}} \approx n/c\alpha_t$$



### EXAMPLE: Output power and photon cavity lifetime $\tau_{ph}$

Consider the He-Ne laser in Example 4.6.1 that has a tube length of 40 cm and  $R_1 = 0.95$  and  $R_2 = 1$ . Suppose that the tube diameter is 0.8 mm, and the output power is 2.5 mW. What are the photon cavity lifetime and the photon concentration inside the cavity? (The emission frequency  $\nu_o$  is 474 THz.)

### Solution

Using  $L = 40$  cm,  $R_1 = 0.95$ ,  $R_2 = 1$ ,  $\alpha_s = 0.05$  m<sup>-1</sup>, gives

$$\begin{aligned}\alpha_t &= \alpha_s + (1/2 L)\ln(R_1 R_2)^{-1} \\ &= 0.05 \text{ m}^{-1} + [2(0.4 \text{ m})]^{-1}\ln[(0.95 \times 1)]^{-1} = 0.114 \text{ m}^{-1},\end{aligned}$$

and hence from Eq.(4.6.12),

$$\tau_{ph} = [(2)(1)(0.4)] / [(3 \times 10^8)(1 - e^{-2 \times 0.114 \times 0.4})] = 30.6 \text{ ns}$$

If we use Eq. (4.6.13) we would find 29.2 ns. To find the photon concentration, we use Eq. (4.6.11)

$$\begin{aligned}P_o &= (0.0025 \text{ W}) \approx 1/2 A(1-R_1)h\nu_o N_{ph} c/n \\ &= 1/2 [\pi(8 \times 10^{-3}/2)^2] (1-0.95)(6.62 \times 10^{-34})(474 \times 10^{12}) N_{ph} (3 \times 10^8)/(1)\end{aligned}$$

which gives

$$N_{ph} \approx 2.1 \times 10^{15} \text{ photons m}^{-3}.$$



# LASER MODES

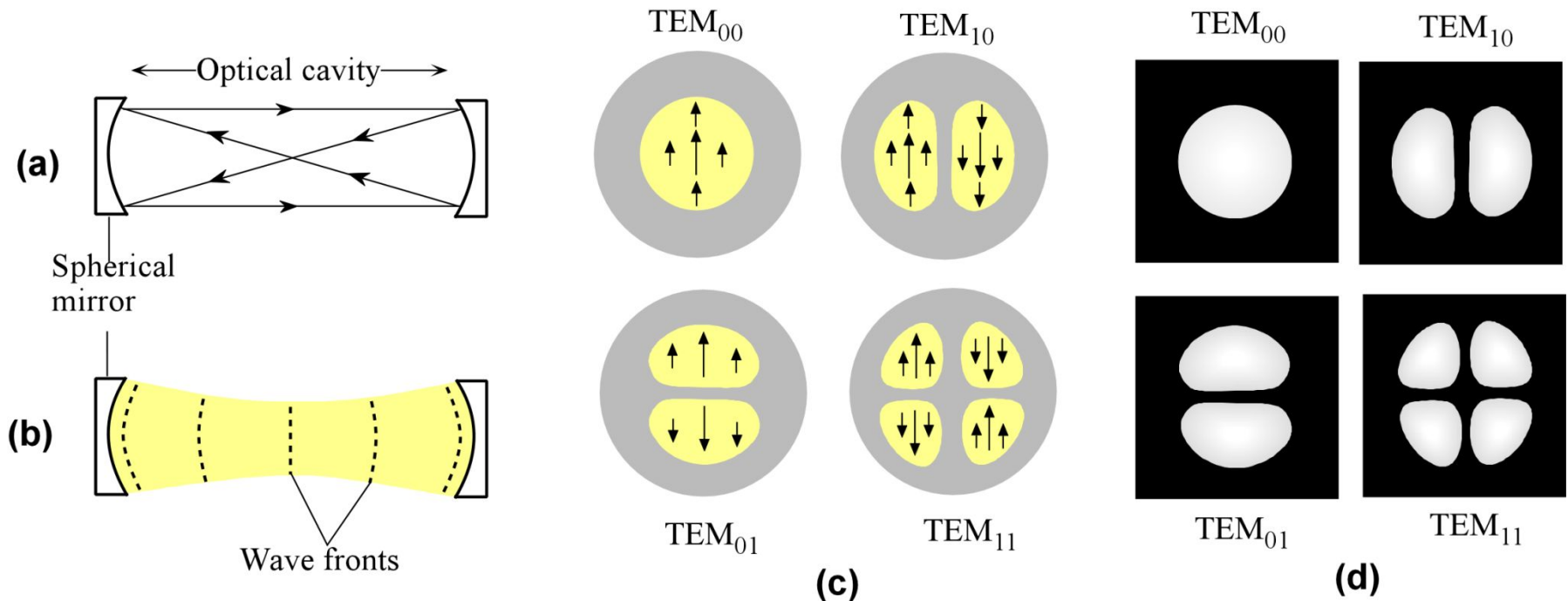

Laser Modes (a) An off-axis transverse mode is able to self-replicate after one round trip. (b) Wavefronts in a self-replicating wave (c) Four low order transverse cavity modes and their fields. (d) Intensity patterns in the modes of (c)



# Homogeneous Broadening

Homogeneous broadening

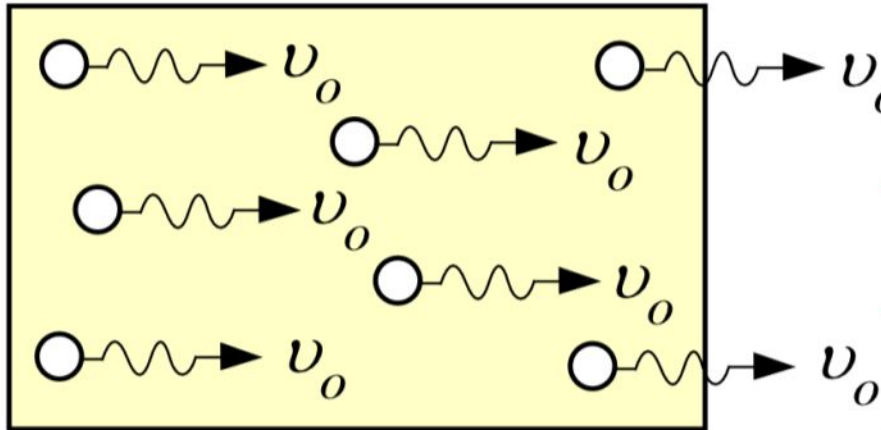

Lorentzian lineshapes

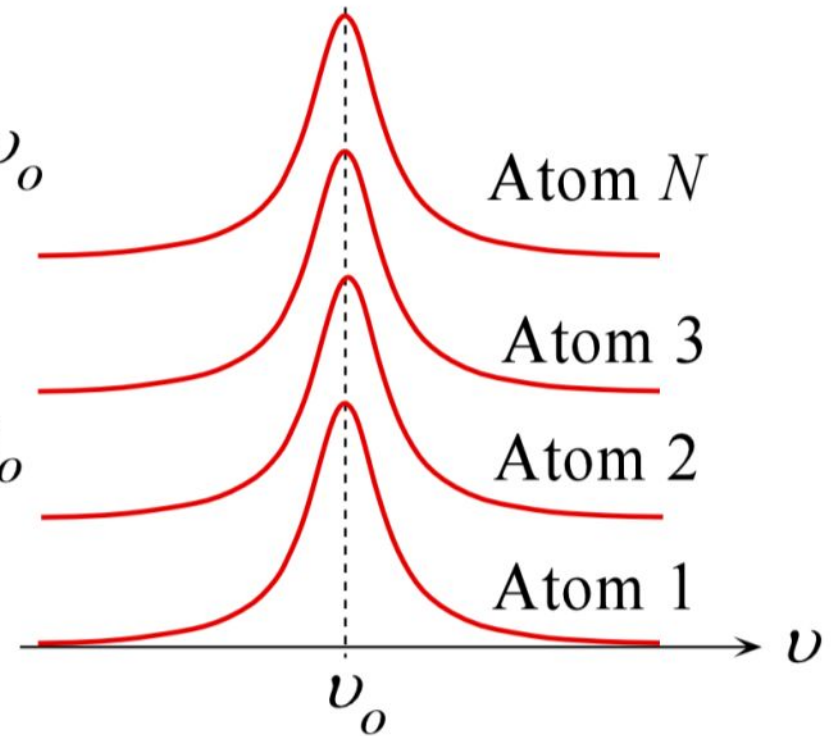

Lineshapes for homogenous broadening. The lineshape is Lorentzian for homogeneous broadening.

# Homogeneous Broadening



$$E(t) = E_0 \exp(-t/2\tau_2) \times \cos(\omega_0 t)$$

$$\int g_L(\nu) d\nu = 1$$

$$g_L(\nu) = \frac{\gamma / \pi}{(\nu - \nu_0)^2 + \gamma^2}$$

## Example:

Lifetime broadening

$1/\gamma = \tau_2$  lifetime of upper state  $E_2$

$$\Delta\nu_{\text{FWHM}} = 2\gamma$$

Lorentzian lineshapes

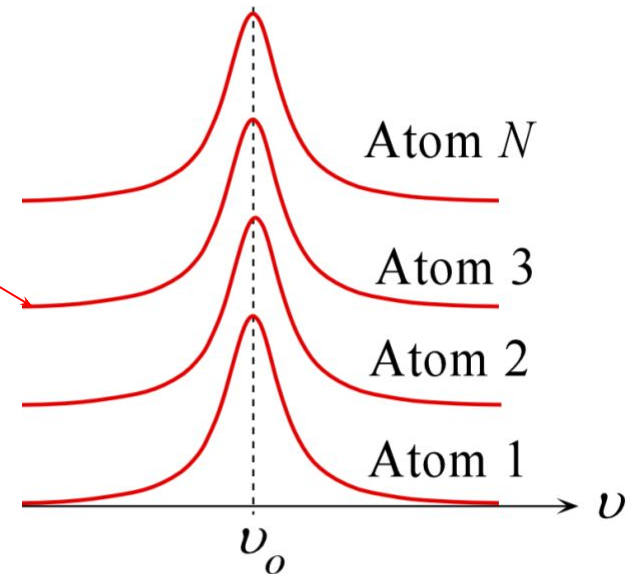



# Inhomogeneous Broadening

Inhomogeneous broadening

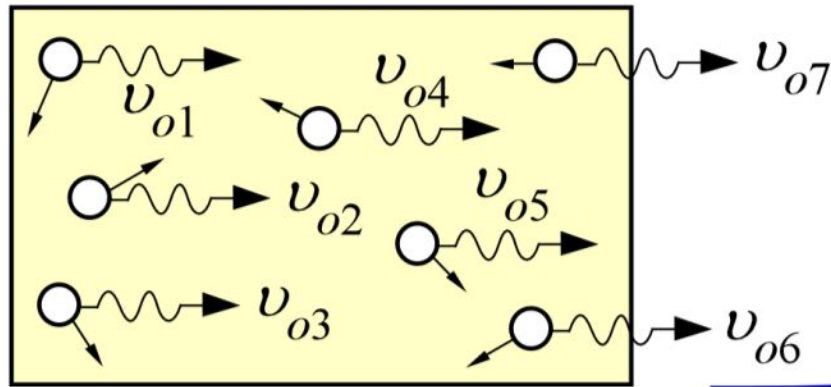

Gaussian lineshape

Individual atomic emissions

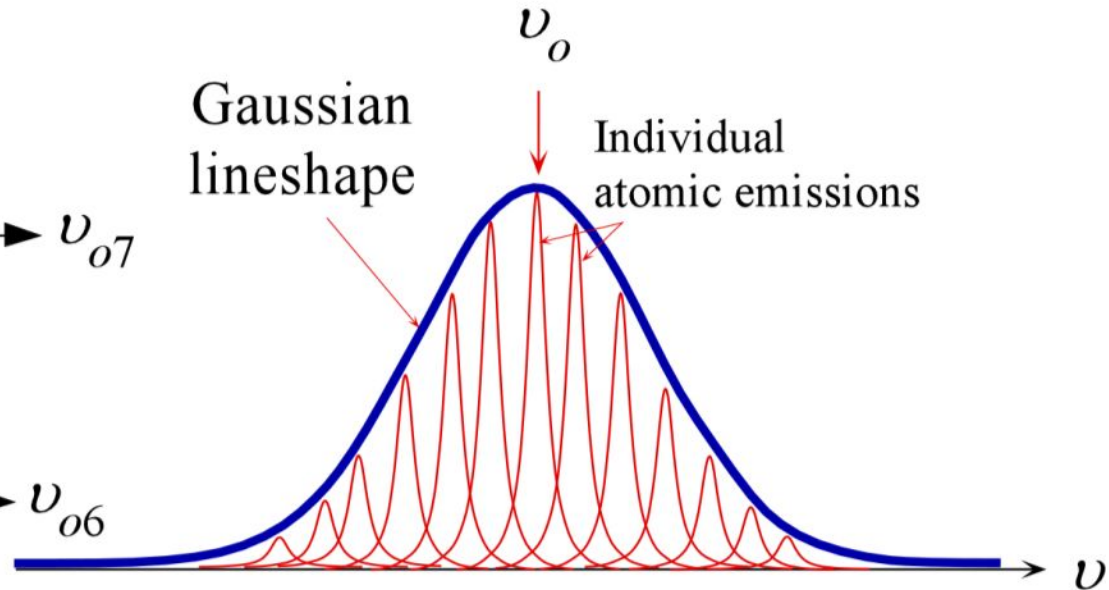

Lineshapes for inhomogeneous broadening. The lineshape is Gaussian for inhomogeneous broadening.





# Inhomogeneous Broadening

$$g_G(\nu) = \frac{1}{\pi^{1/2}\Gamma} \exp[-(\nu - \nu_o)^2 / \Gamma^2]$$

$$\int g_L(\nu) d\nu = 1$$

$$\Delta\nu_{\text{FWHM}} = 2\Gamma[\ln(2)]^{1/2}$$

## Doppler broadening in gas lasers

$$\Delta\nu_{1/2} = 2\nu_o \sqrt{\frac{2k_B T \ln(2)}{Mc^2}}$$

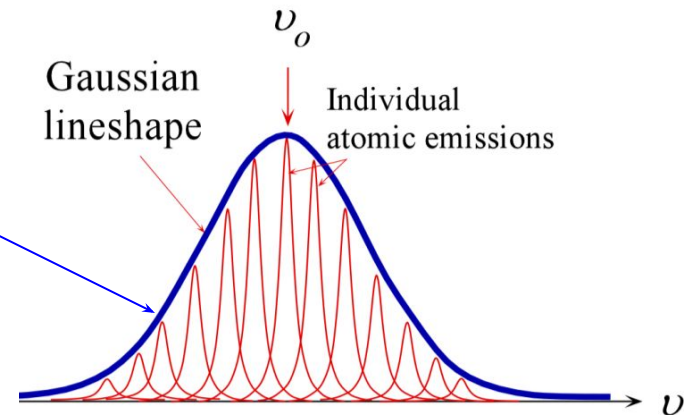

# Broadening

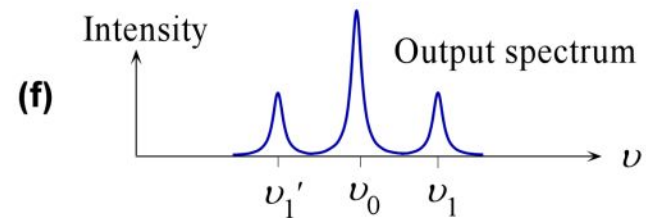
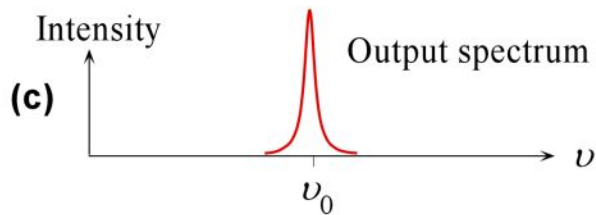
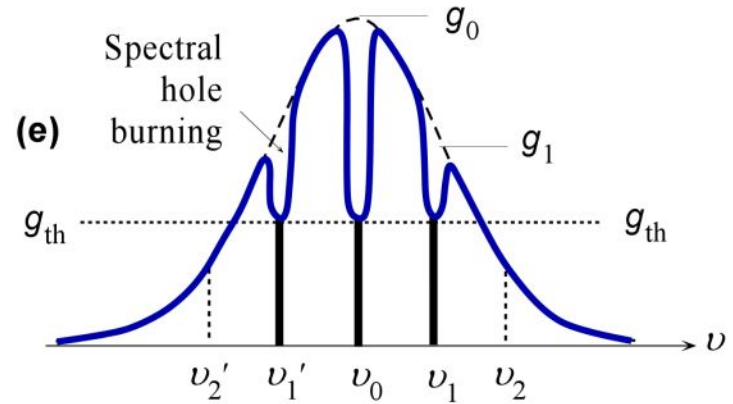
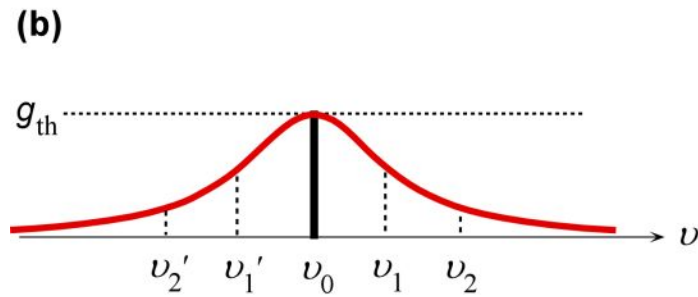
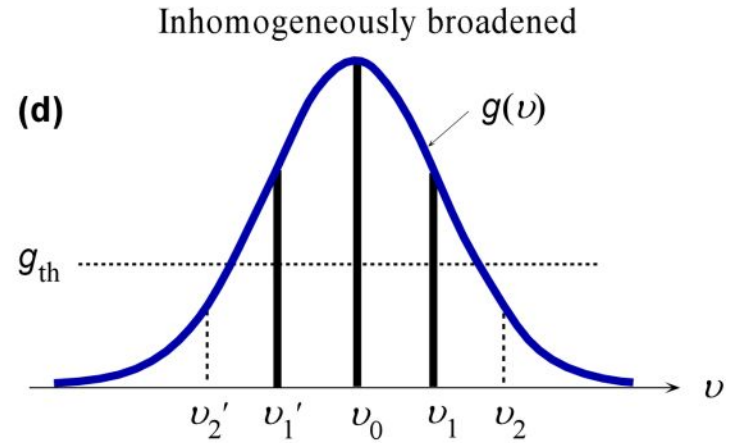
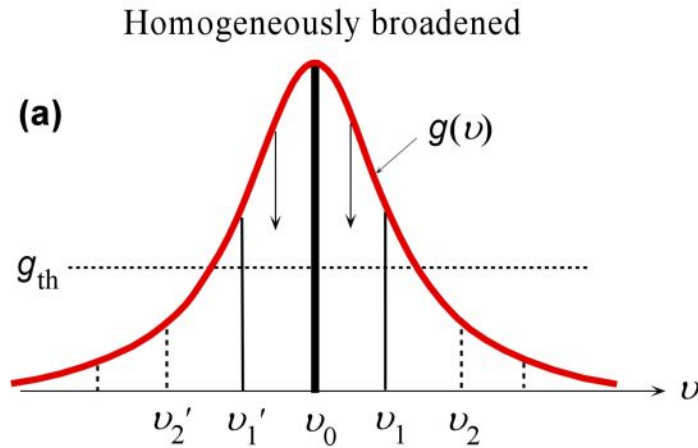

# Spectral Hole Burning

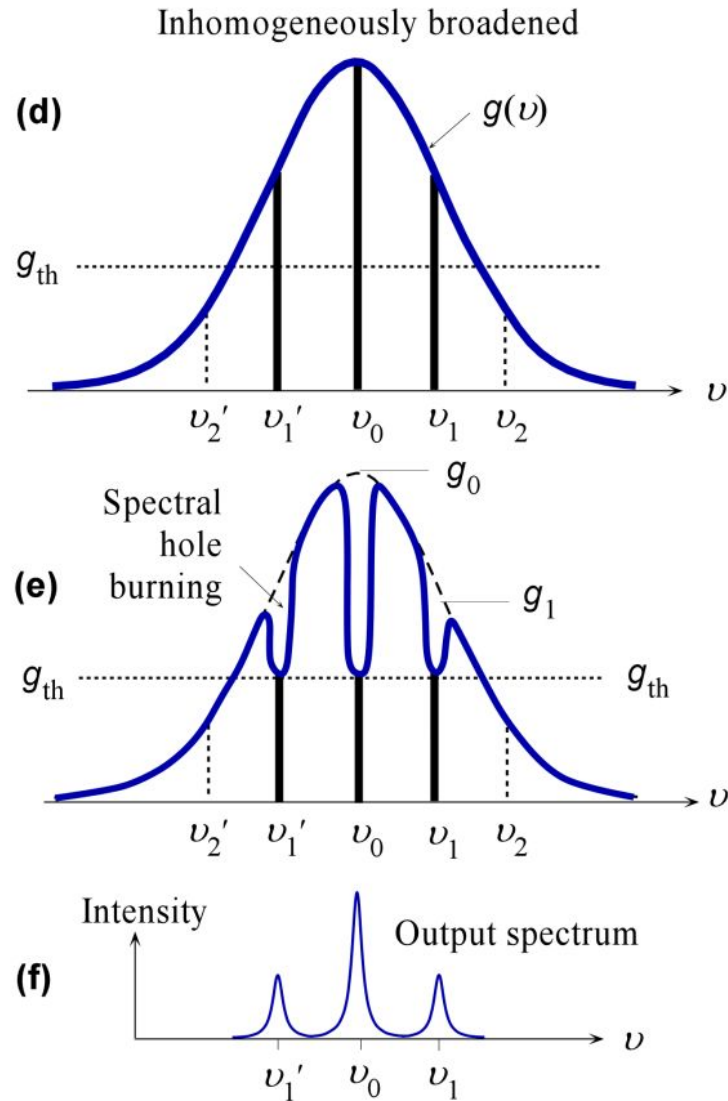



# Broadening

**Homogenous  
broadening**  
Lorentzian lineshapes

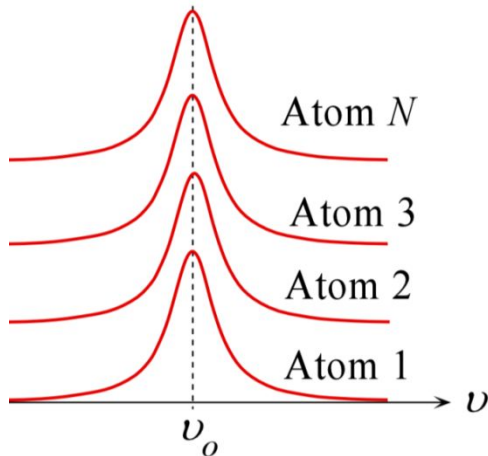

**Inhomogeneous  
broadening**

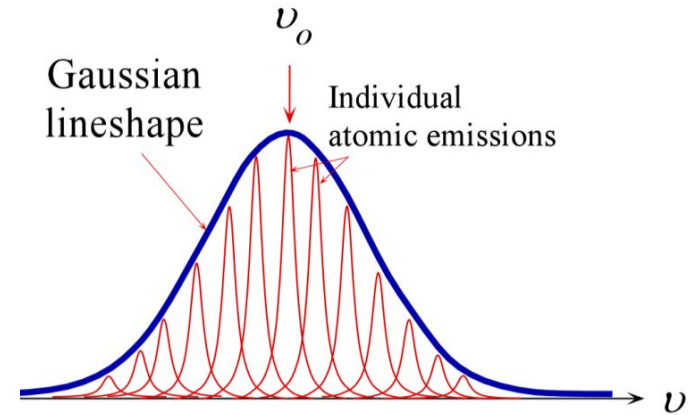

	Main characteristics	Lineshape	Examples of lasers
<b>Homogeneous broadening</b>	All atoms emit the same spectrum with the same center frequency $\nu_0$ . Single mode lasing output	Lorentzian function	Nd <sup>3+</sup> :YAG; phonon collision broadening Pressure broadening in CO <sub>2</sub> lasers
<b>Inhomogeneous broadening</b>	Different atoms emit at slightly differing central frequencies, due to random processes shifting the peak frequency Multi-mode or single mode lasing output	Gaussian function	He-Ne lasers; Doppler broadening Nd <sup>3+</sup> :glass lasers; amorphous structure broadening

# Q-Switching

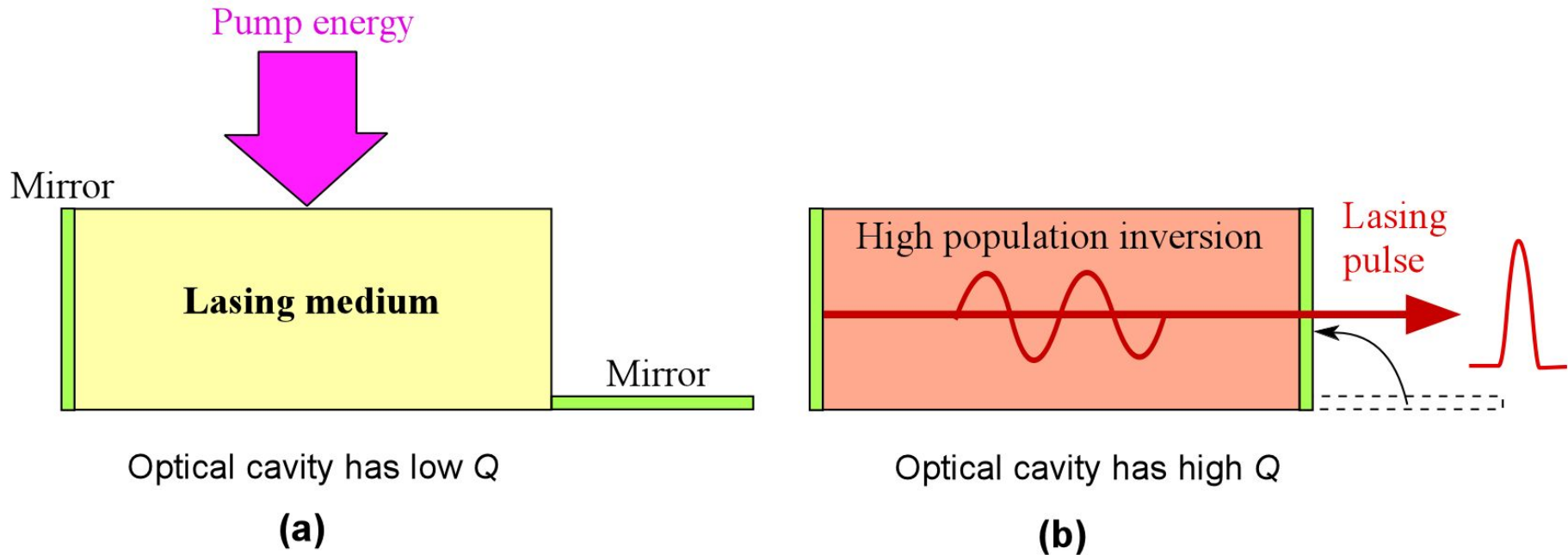

- (a) The optical cavity has a low  $Q$  so that pumping takes the atoms to a very high degree of population inversion; lasing is prevented by not having a right hand mirror.
- (b) The right mirror is "flung" to make an optical resonator,  $Q$  is switched to a high value which immediately encourages lasing emissions. There is an intense pulse of lasing emission which brings down the excess population inversion.



# Q-Switching

A simplified schematic of Q-switching in the generation of short laser pulses. (a) The pump profile *i.e.* the flash tube output. (b) The evolution of the population difference  $N_2 - N_1$  with time. (c) The switching of the optical cavity  $Q$  during the pumping procedure while the population inversion is very large and greater than the normal threshold population. (d) The output light pulse.

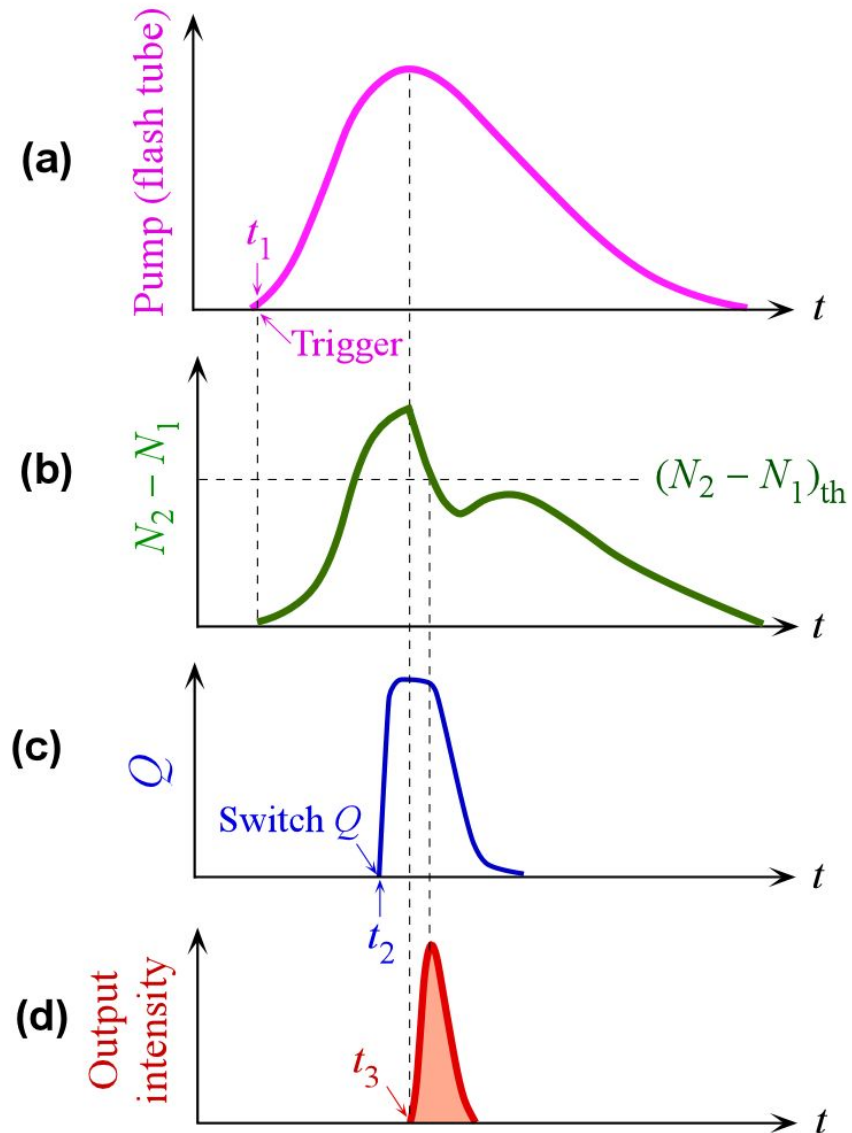



# Q-Switching

Selected typical characteristics of two commercial Q-switched Nd<sup>3+</sup>:YAG lasers.  
Usually higher energy output pulses require operation at a lower repetition frequency.

Laser	Nd <sup>3+</sup> :YAG NL220 by EKSPLA	Nd <sup>3+</sup> :YAG P-1064-150-HE by Alphas
Emission wavelength (nm)	1064	1064
Output pulse energy (mJ)	10	1.5
Pulse width (ns)	7	1.1
Repetition rate (Hz)	1000	100
Peak power (kW)	~1,400	~1,400
Q-switch	EO	Passive
Output beam	TEM <sub>00</sub>	TEM <sub>00</sub>
Output beam $M^2$	<1.5	–
Beam divergence (mrad)	< 1.5	6
Beam diameter (mm)	2.5	0.3

# Q-Switching

(a) Q-switching by using a rotating prism. (b) Q-switching by using a saturable absorber. (c) Q-switching by using an electro-optic (EO) switch. Normally a polarizer is also needed before or after the switch but this is part of the EO switch in this diagram.

(a)

(b)

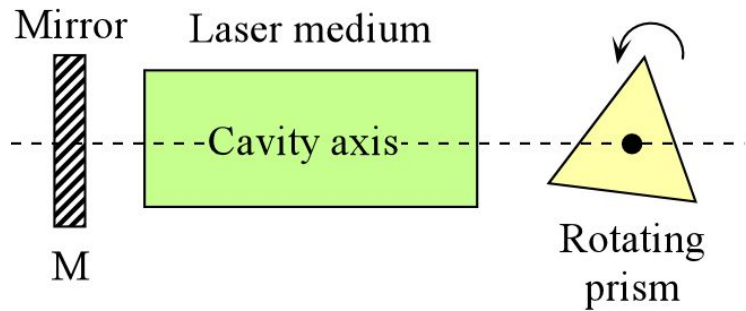

(c)

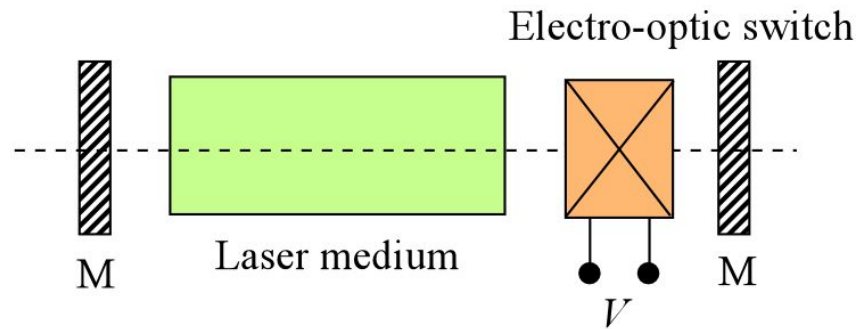
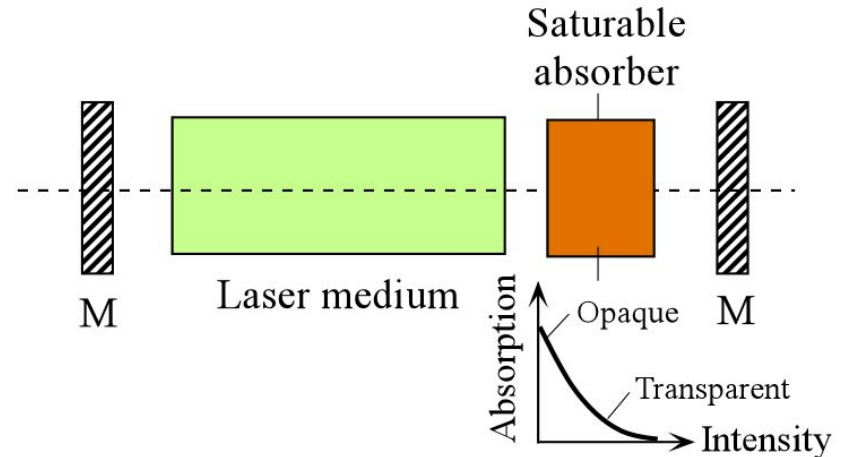



# Mode-Locking

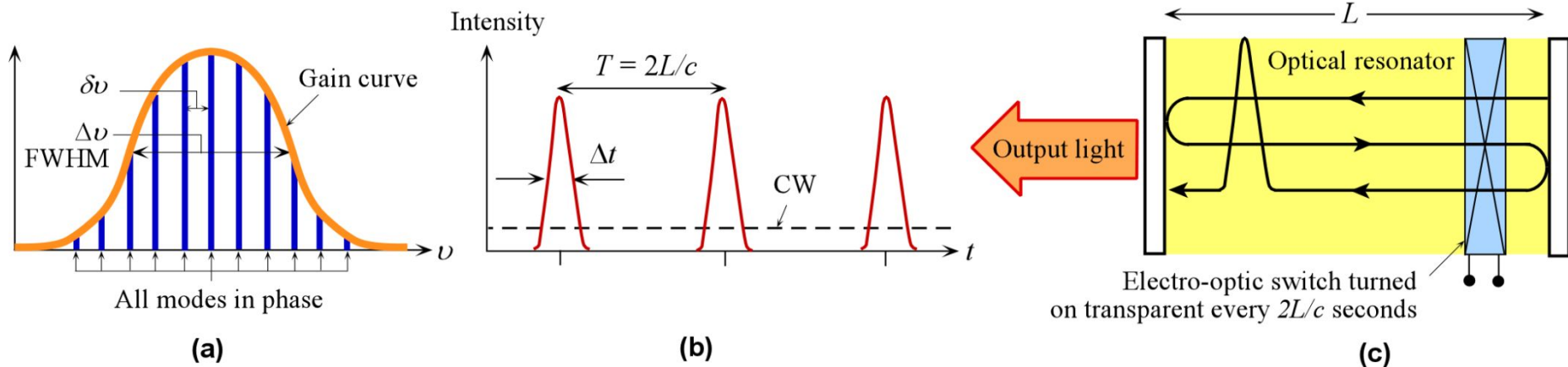

(a) A mode-locked laser has its  $N$  modes all in phase so that the modes add correctly to generate a short laser pulse every  $T$  seconds.  $\Delta\nu$  is the full width at half maximum (FWHM). (b) The output light intensity from a mode locked laser is a periodic series of short intense optical pulses that are separated in time by  $T = 2L/c$ , the round trip time for the pulse in the resonator. (c) A laser can be mode-locked by using an EO switch in the optical cavity that becomes transparent exactly at the right time, every  $T$  seconds. Each time the pulse in the resonator impinges on the left mirror, every  $T = 2L/c$  seconds, a portion of it is transmitted, which constitutes the output from a mode-locked laser



# Semiconductor Laser Diode

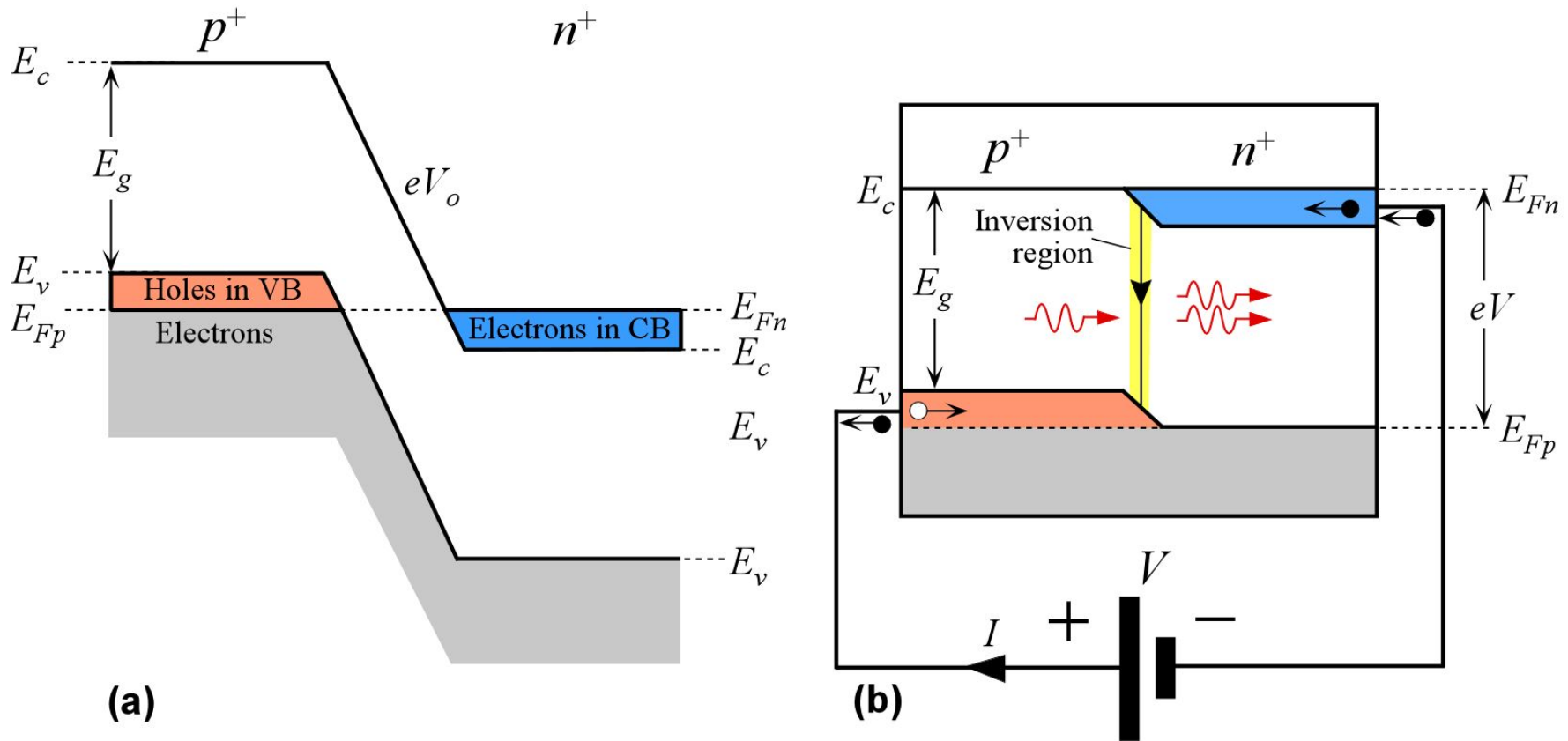

(a) The energy band diagram of a degenerately doped  $pn$  with no bias. (b) Band diagram with a sufficiently large forward bias to cause population inversion and hence stimulated emission.



# Semiconductor Laser Diode

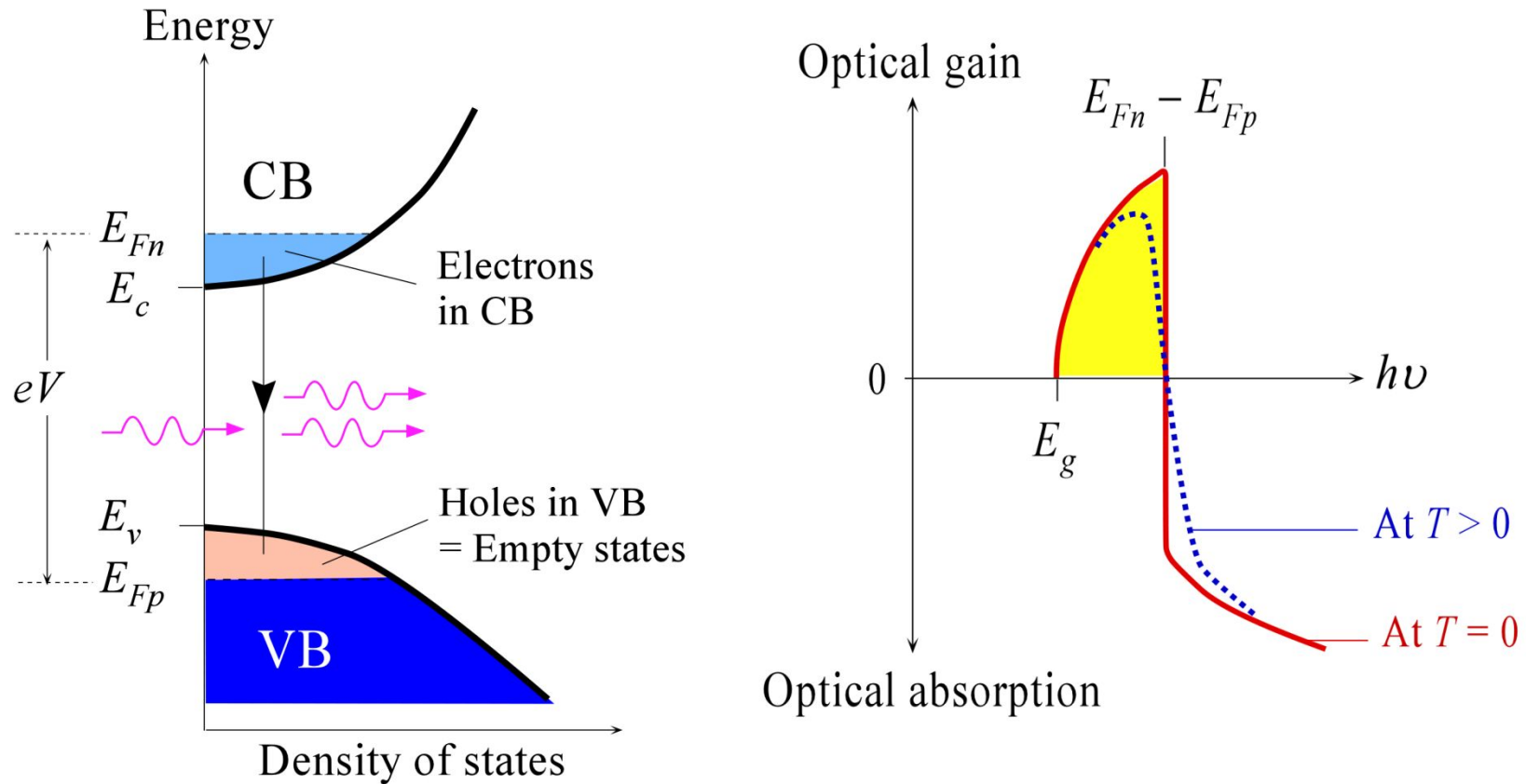

(a) The density of states and energy distribution of electrons and holes in the conduction and valence bands respectively at  $T > 0$  in the SCL under forward bias such that  $E_{Fn} - E_{Fp} > E_g$ . Holes in the VB are empty states. (b) Gain vs. photon energy ( $h\nu$ ).



# Semiconductor Laser Diode

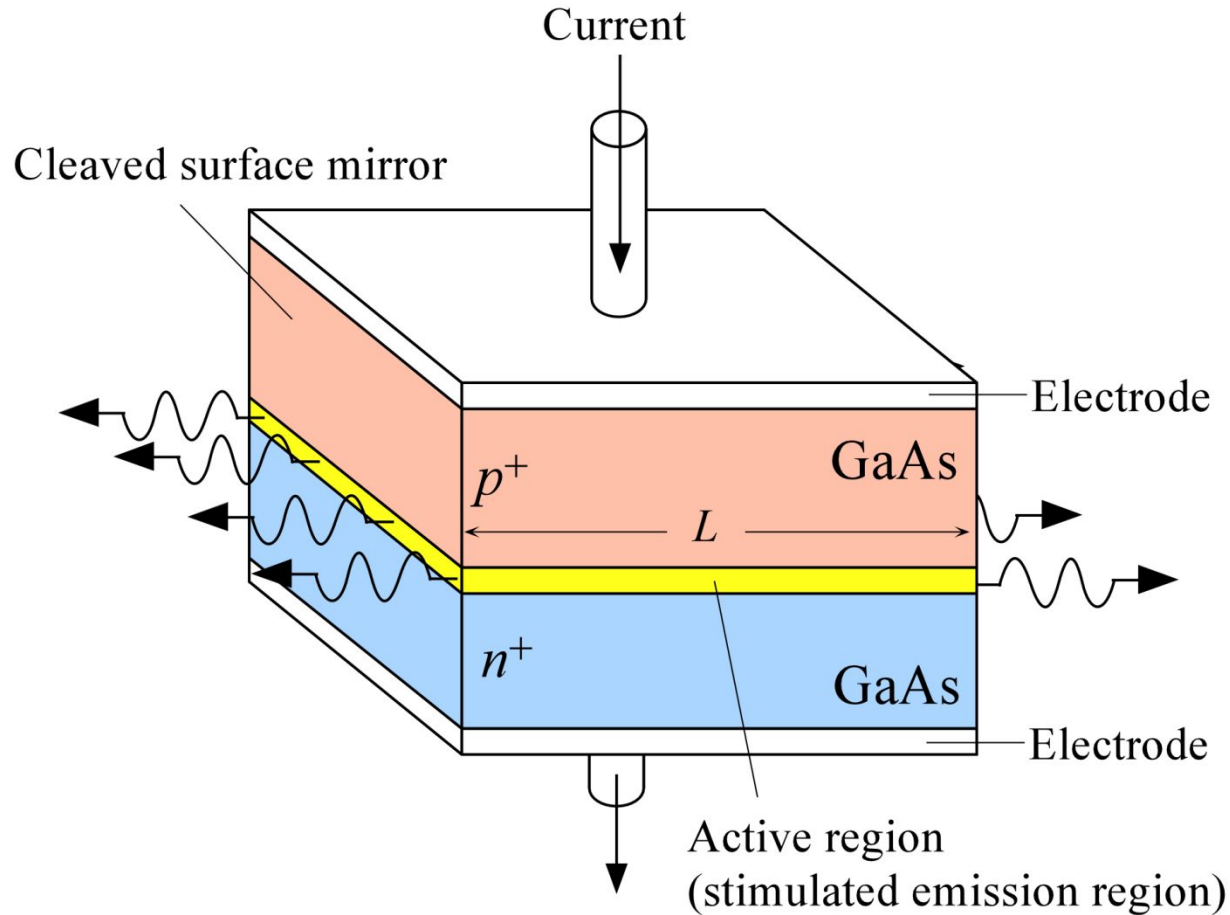

A schematic illustration of a GaAs homojunction laser diode. The cleaved surfaces act as reflecting mirrors.



# Semiconductor Laser Diode

Robert Hall and his colleagues, while working at General Electric's Research and Development Center in Schenectady, New York, were among the first groups of researchers to report a working semiconductor laser diode in 1962. He obtained a US patent in 1967, entitled "Semiconductor junction laser diode" for his invention. When Robert Hall retired from GE in 1987, he had been awarded more than forty patents. (R.N. Hall, *et al*, *Phys Rev Letts*, 9, 366, 1962.) (Courtesy of GE)

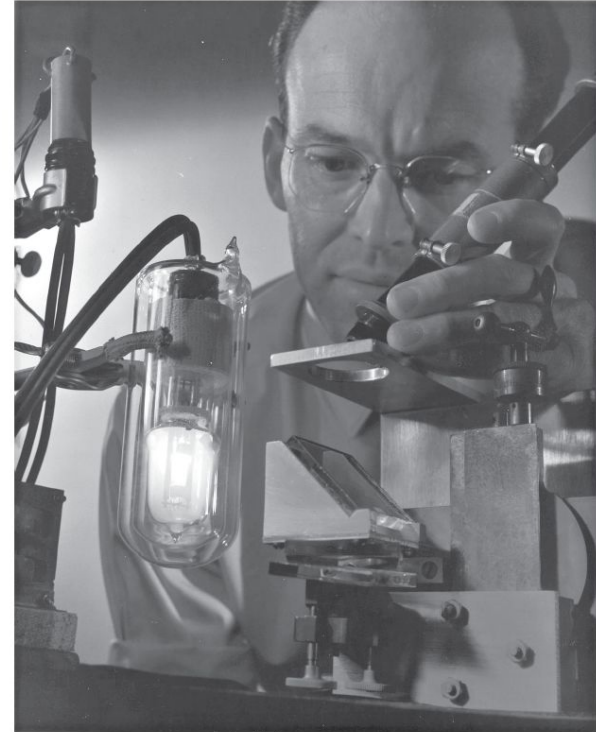



# Semiconductor Laser Diode Output

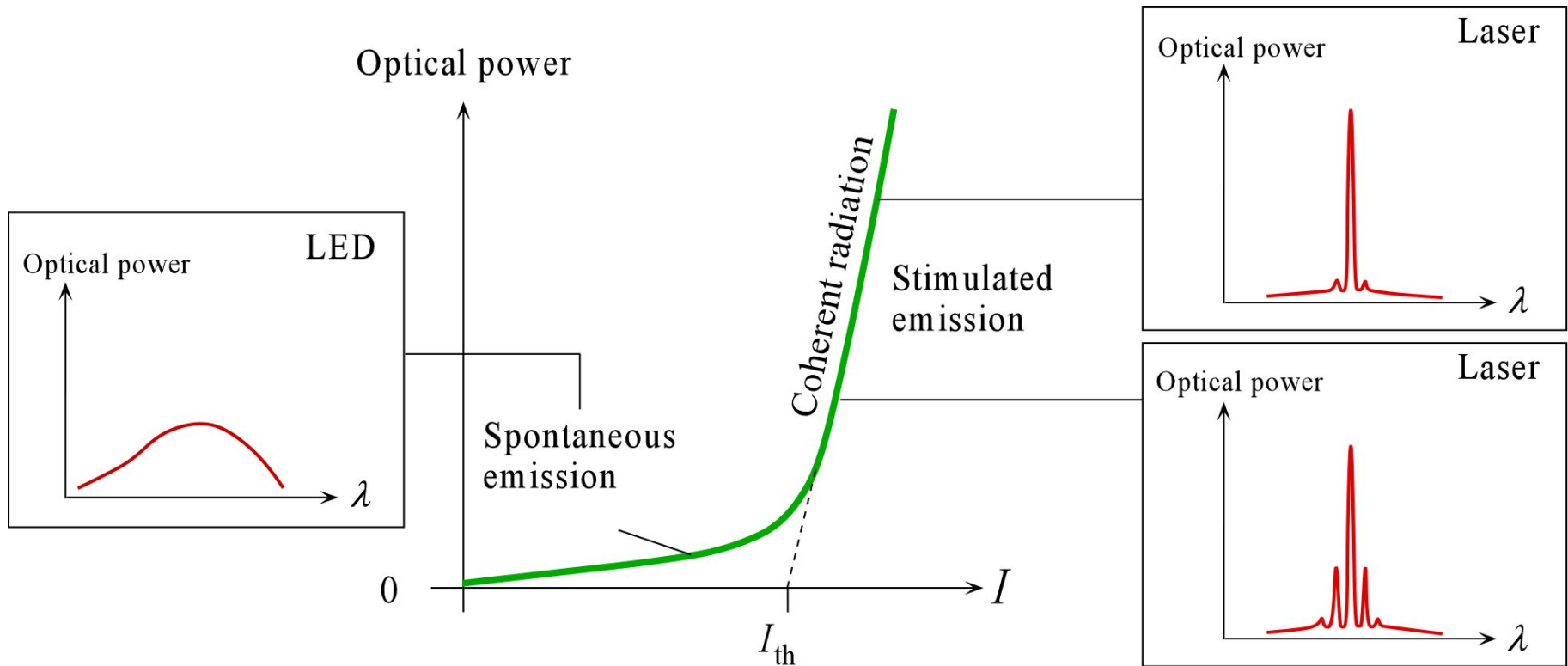

Typical output optical power vs. diode current ( $I$ ) characteristics and the corresponding output spectrum of a laser diode.  $I_{th}$  is the threshold current and corresponds to the extension of the coherent radiation output characteristic onto the  $I$ -axis.

# Double Heterostructure Laser Diode

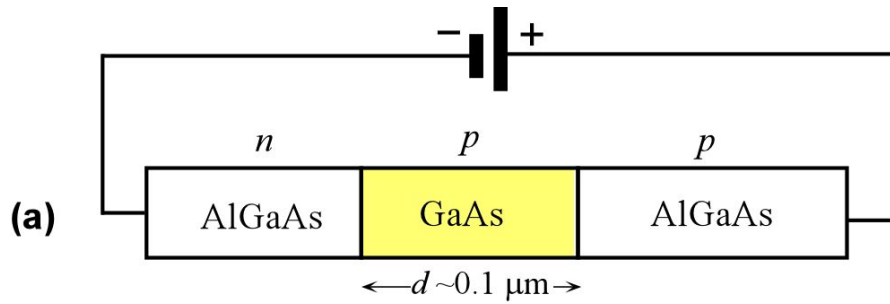

A double heterostructure diode has two junctions which are between two different bandgap semiconductors (GaAs and AlGaAs).

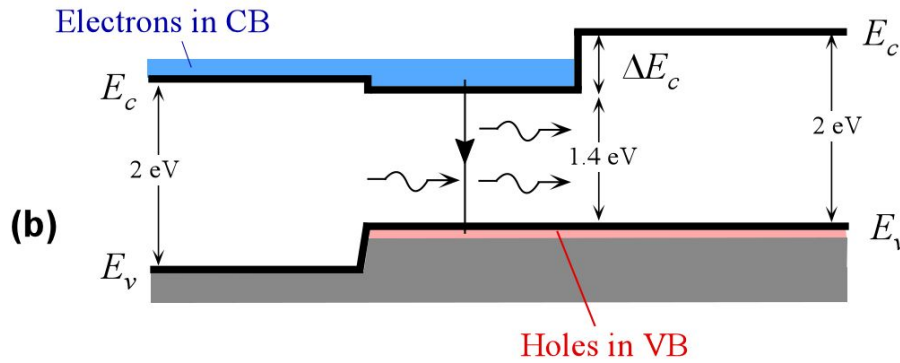

Simplified energy band diagram under a large forward bias. Lasing recombination takes place in the *p*-GaAs layer, the *active layer*.

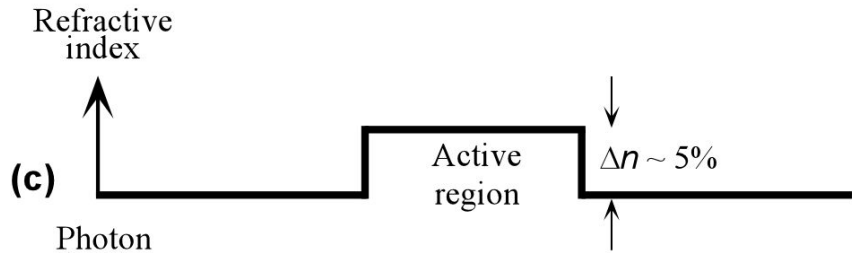

Higher bandgap materials have a lower refractive index.

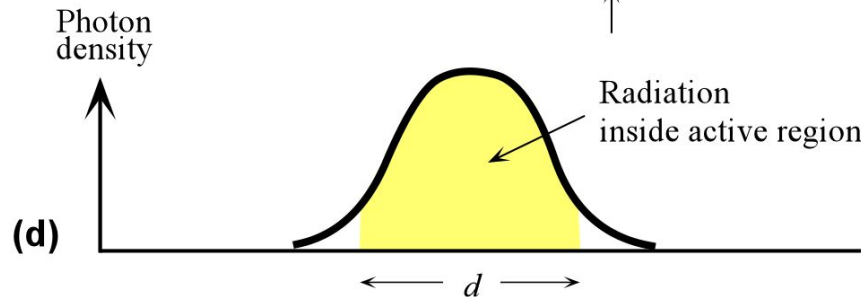

AlGaAs layers provide lateral optical confinement.

# Double Heterostructure Laser Diode



Izuo Hayashi (left) and Morton Panish (1971) at Bell Labs were able to design the first semiconductor laser that operated continuously at room temperature. The need for semiconductor heterostructures for efficient laser diode operation was put forward by Herbert Kroemer in the USA and Zhores Alferov in Russia in 1963. *(Reprinted with permission of Alcatel–Lucent USA Inc.)*





# Stripe Geometry Laser Diode

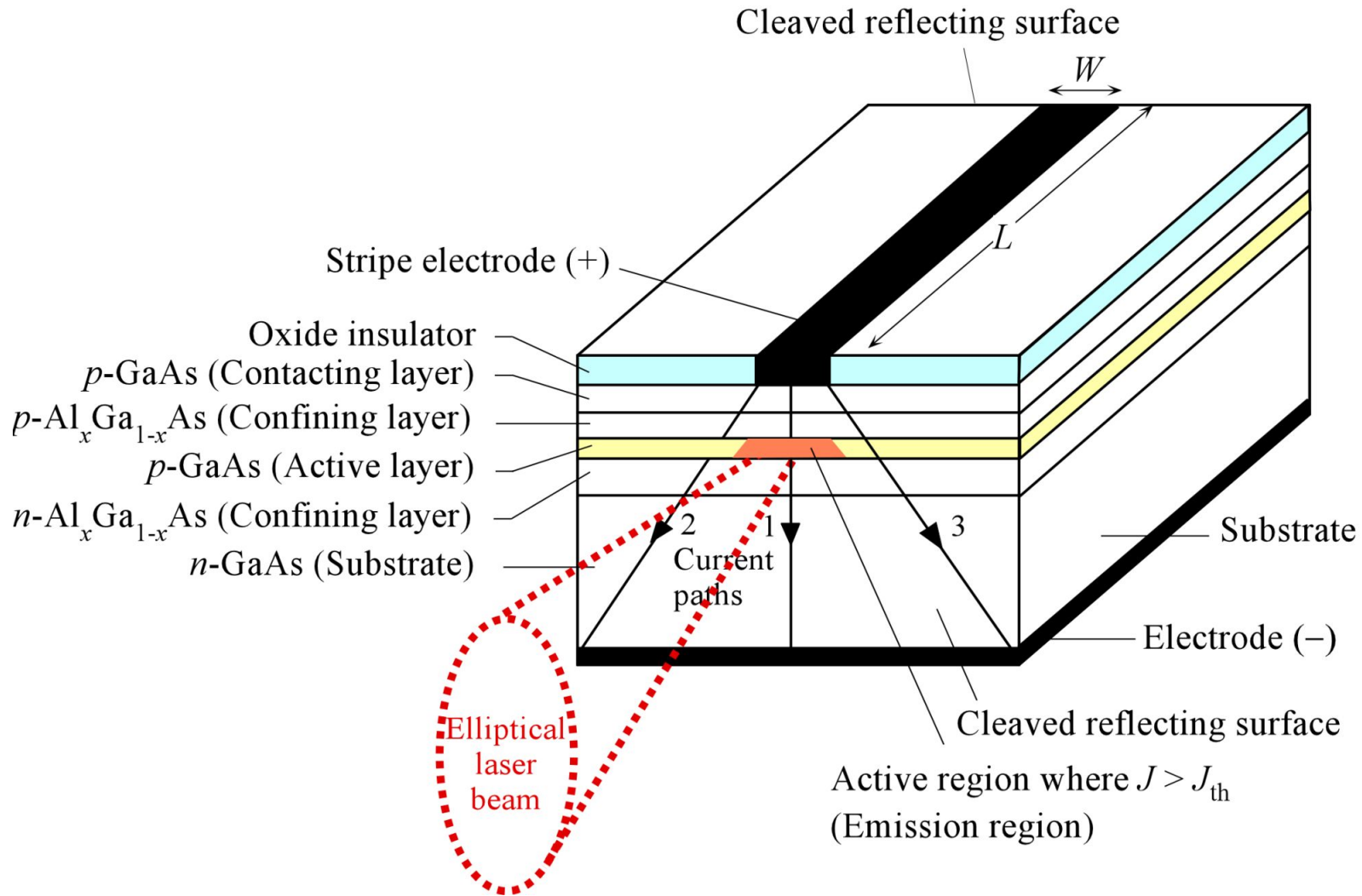

Schematic illustration of the structure of a double heterojunction stripe contact laser diode



# Buried Double Heterostructure

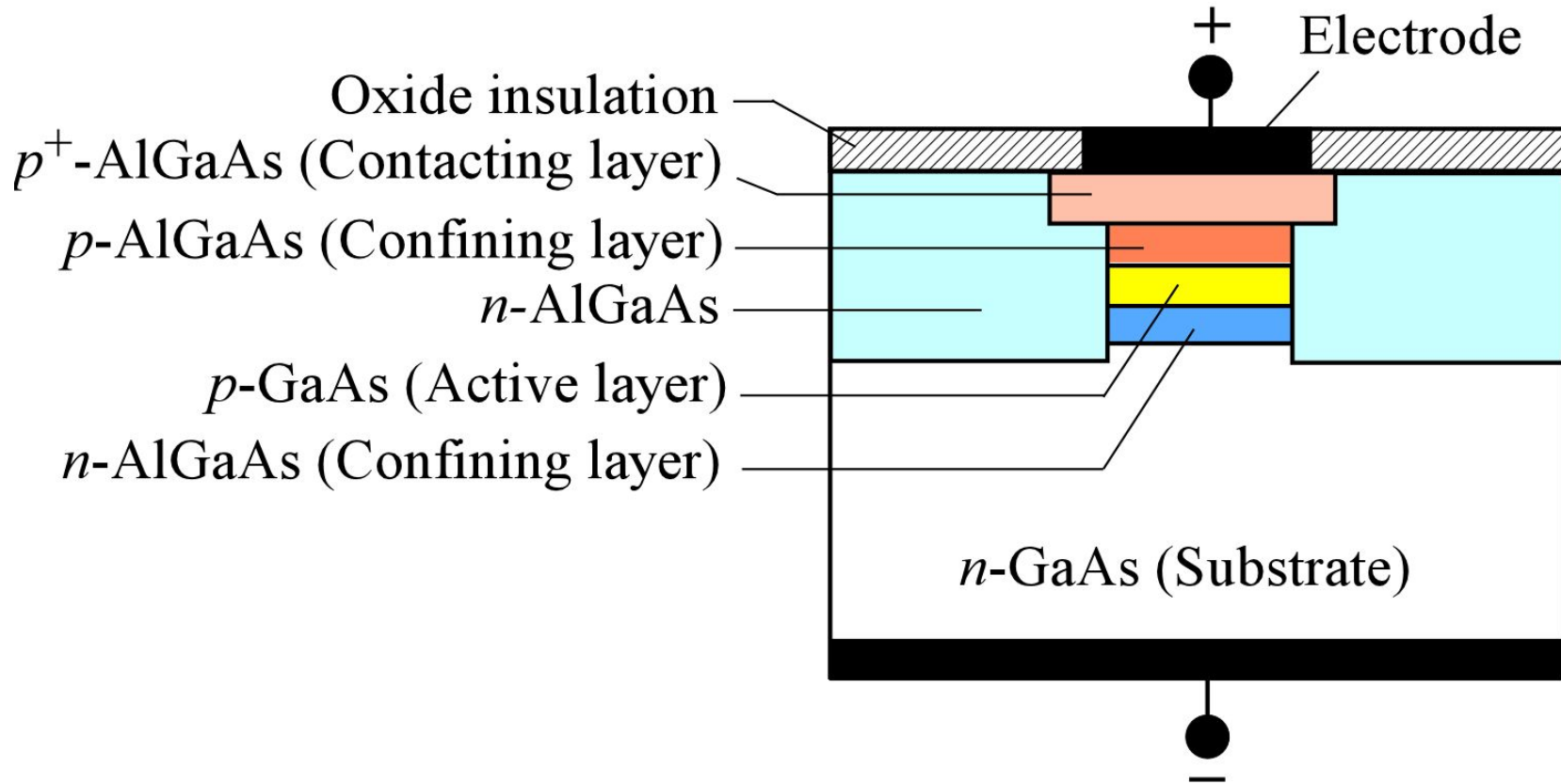

A simplified schematic diagram of a double heterostructure semiconductor laser device that has its active region *buried* within the device in such a way that it is surrounded by low refractive index materials rendering the active region as a waveguide.

# Buried Double Heterostructure

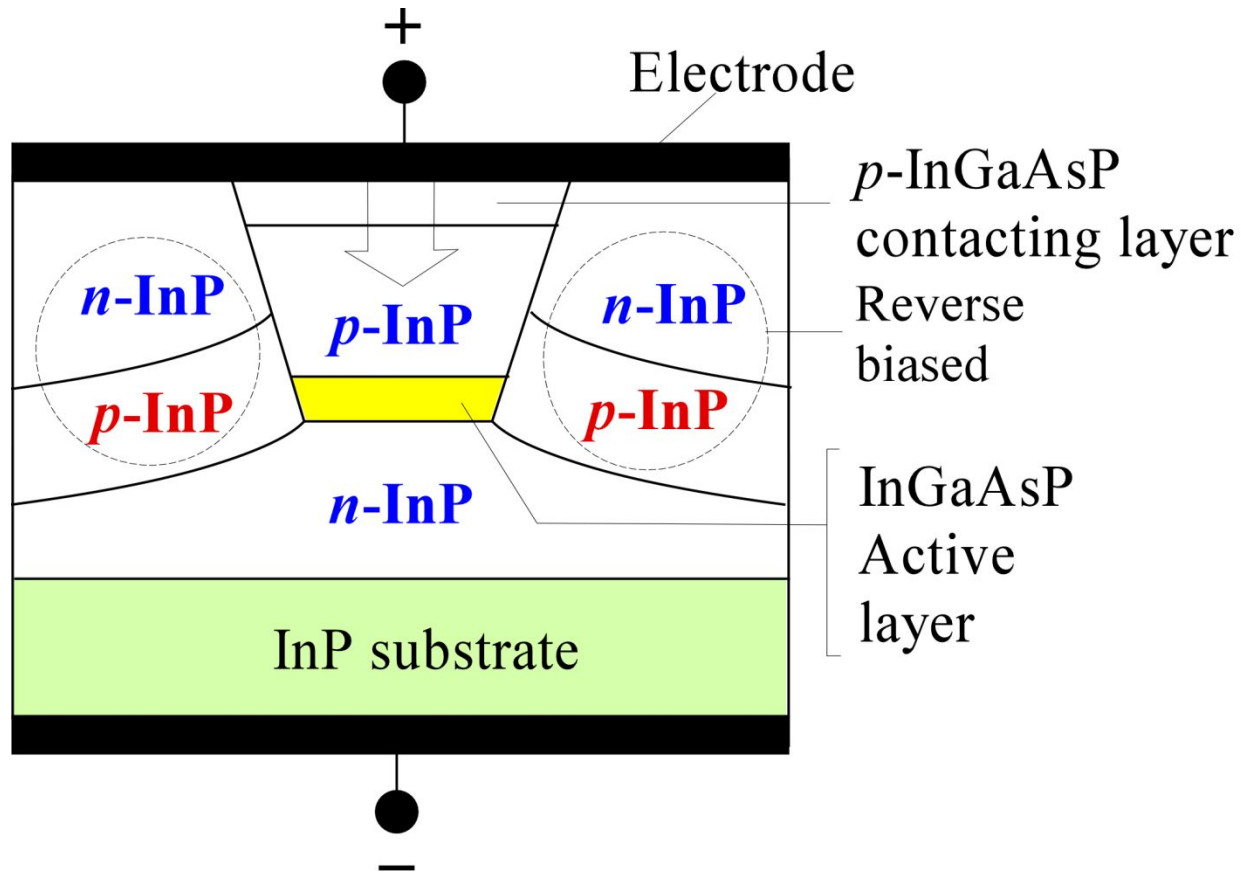

A highly simplified schematic sketch of a buried heterostructure laser diode for telecom applications. The active layer (InGaAsP) is surrounded by the wider bandgap, lower refractive index InP material. Layers are grown on an InP substrate. The InP  $np$  junction is reverse biased and prevents the current flow outside the central active region.

# Semiconductor Laser Diodes

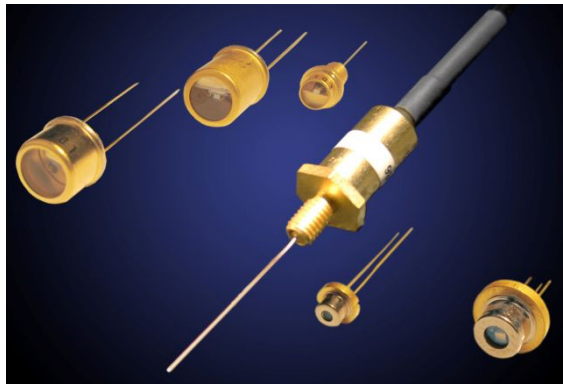
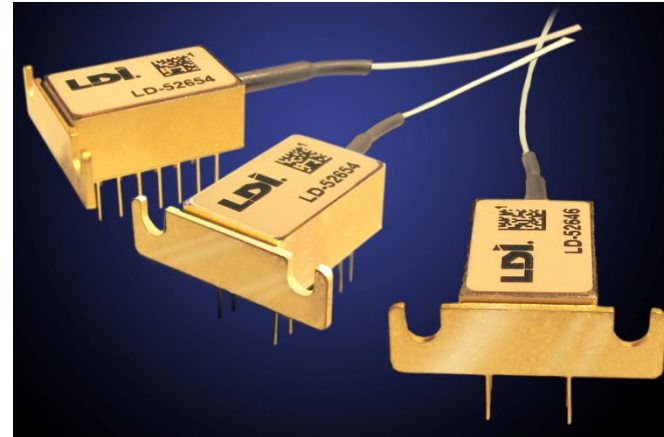
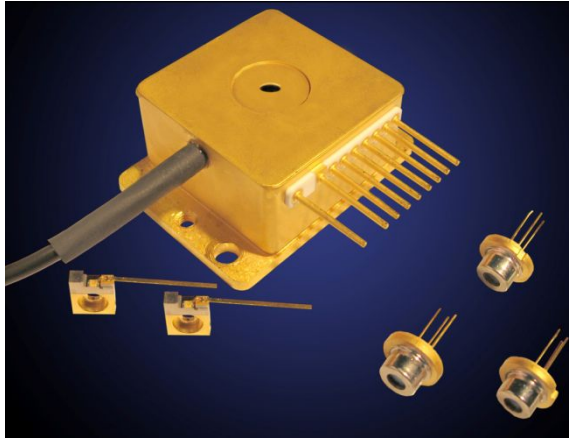

Top left: High power (0.5 – 7 W) CW laser diodes with emission at 805 nm and a spectral width of 2.5 nm. Applications include medical systems, diode pumped lasers, analytical equipment, illuminators, reprographics, laser initiated ordnance *etc.* Top right: Typical pigtailed laser diodes for telecom. These are Fabry-Perot laser diodes operating at peak wavelengths of 1310 and 1550 nm with spectral widths of 2 and 1.3 nm respectively. The threshold currents are 6 mA and 10 mA, and they can deliver 2 mW of optical power into a single mode fiber. Lower left: High power 850 and 905 nm pulsed laser diodes for use in range finders, ceilometers, weapon simulation, optical fuses, surveying equipment *etc.* (Courtesy of OSI Laser Diode Inc.)



## EXAMPLE: Modes in a laser and the optical cavity length

Consider an AlGaAs based heterostructure laser diode that has an optical cavity of length 200  $\mu\text{m}$ . The peak radiation is at 870 nm and the refractive index of GaAs is about 3.6. What is the mode integer  $m$  of the peak radiation and the separation between the modes of the cavity? If the optical gain vs. wavelength characteristics has a FWHM wavelength width of about 6 nm how many modes are there within this bandwidth? How many modes are there if the cavity length is 20  $\mu\text{m}$ ?

### Solution

Figure 4.19 schematically illustrates the cavity modes, the optical gain characteristics, and a typical output spectrum from a laser. The wavelength  $\lambda$  of a cavity mode and length  $L$  are related by Eq. (4.9.1),  $m(1/2)(\lambda/n) = L$ , where  $n$  is the refractive index of the semiconductor medium, so that

$$m = \frac{2nL}{\lambda} = \frac{2(3.6)(200 \times 10^{-6})}{(870 \times 10^{-9})} = 1655.1$$

The wavelength separation  $\Delta\lambda_m$  between the adjacent cavity modes  $m$  and  $(m+1)$  in Figure 4.19 is

$$\Delta\lambda_m = \frac{2nL}{m} - \frac{2nL}{m+1} \approx \frac{2nL}{m^2} = \frac{\lambda^2}{2nL}$$

where we assumed that the refractive index  $n$  does not change significantly with wavelength from one mode to another. Thus the separation between the modes for a given peak wavelength increases with decreasing  $L$ .



## EXAMPLE: Modes in a laser and the optical cavity length

### Solution (continued)

When  $L = 200 \mu\text{m}$ ,

$$\Delta\lambda_m = \frac{(870 \times 10^{-9})^2}{2(3.6)(200 \times 10^{-6})} = 5.26 \times 10^{-10} \text{ m or } 0.526 \text{ nm}$$

If the optical gain has a bandwidth of  $\Delta\lambda_{1/2}$ , then there will be  $\Delta\lambda_{1/2}/\Delta\lambda_m$  number of modes, or  $(6 \text{ nm})/(0.526 \text{ nm})$ , that is 11 modes.

When  $L = 20 \mu\text{m}$ , the separation between the modes becomes,

$$\Delta\lambda_m = \frac{(870 \times 10^{-9})^2}{2(3.6)(20 \times 10^{-6})} = 5.26 \text{ nm}$$

Then  $(\Delta\lambda_{1/2})/\Delta\lambda_m = 1.14$  and there will be one mode that corresponds to about 870 nm. In fact  $m$  must be an integer so that choosing the nearest integer,  $m = 166$ , gives  $\lambda = 867.5 \text{ nm}$  (choosing  $m = 165$  gives 872.7 nm) It is apparent that reducing the cavity length suppresses higher modes. Note that the optical bandwidth depends on the diode current.

# Quantum Well Lasers

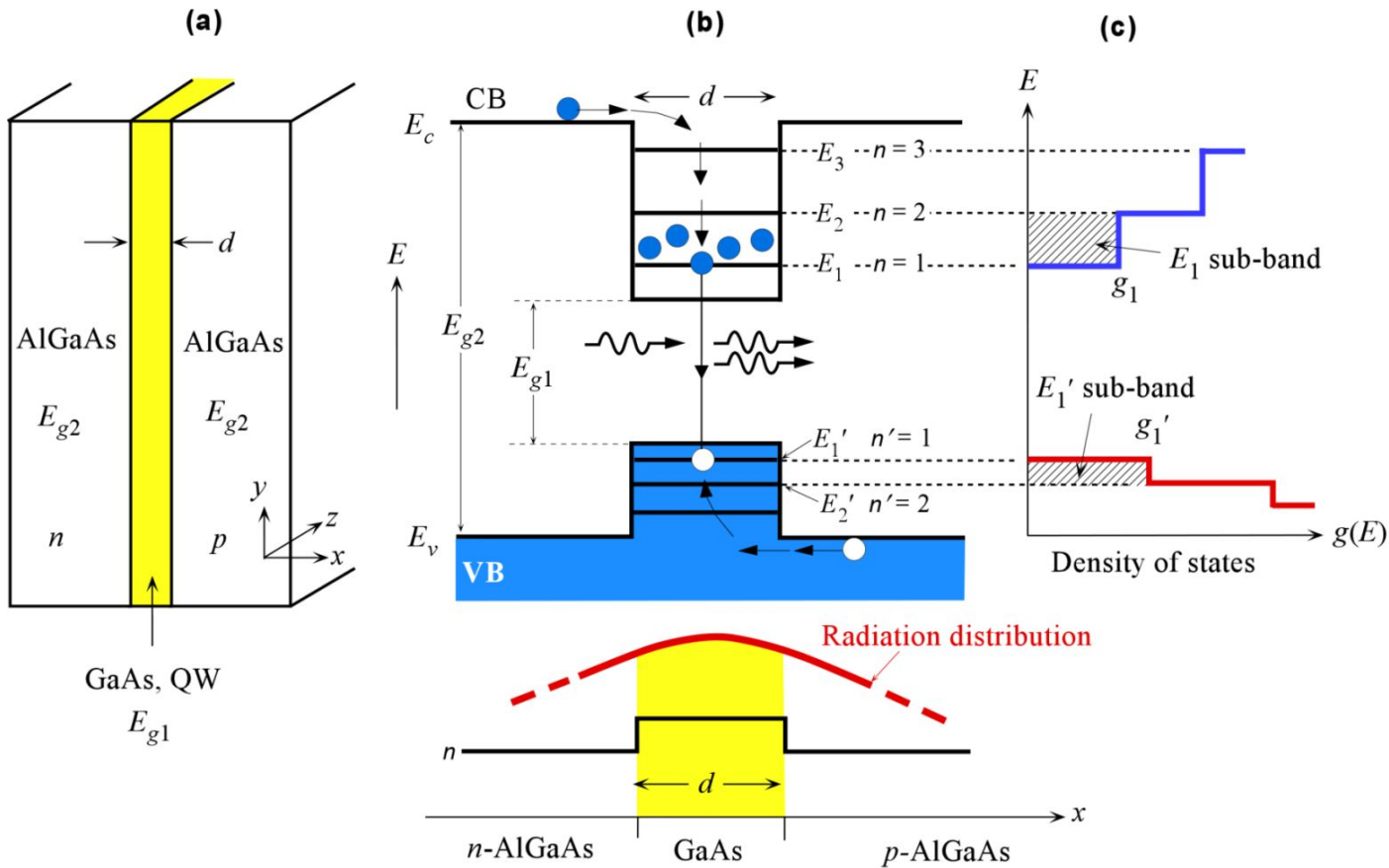

(a) A single quantum well (SQW) of bandgap  $E_{g1}$  sandwiched between two semiconductors of wider bandgap  $E_{g2}$ ,  
 (b) The electron energy levels, and stimulated emission. The electrons and holes are injected from  $n$ -AlGaAs and  $p$ -AlGaAs respectively. The refractive index variation tries to confine the radiation to GaAs but  $d$  is too thin, and most of the radiation is in the AlGaAs layers rather than within  $d$ . (c) The density of states  $g(E)$  is a step-like function, and is finite at  $E_1$  and  $E_1'$ . The  $E_1$  sub-band for electrons and  $E_1'$  sub-band for holes are also shown. The electrons in the  $E_1$  sub-band have kinetic energies in the  $yz$ -plane.

# Quantum Well Lasers

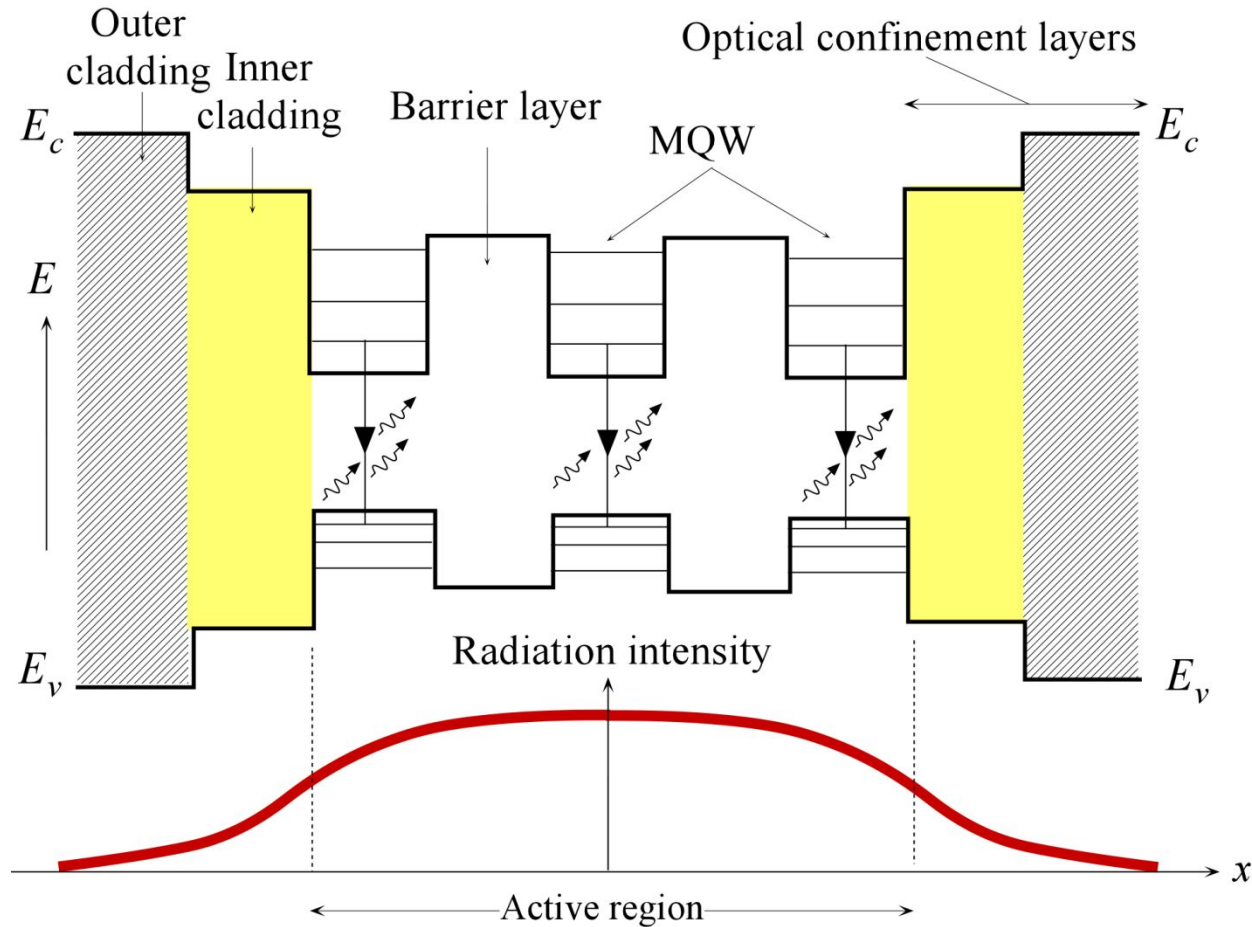

A simplified schematic diagram of multiple quantum well (MQW) heterostructure laser diode. Electrons are injected by the forward current into quantum wells. The light intensity distribution is also shown. Most of the light is in the active region.





## EXAMPLE: A GaAs quantum well

Consider a very thin GaAs quantum well sandwiched between two wider bandgap semiconductor layers of AlGaAs ( $\text{Al}_{0.33}\text{Ga}_{0.67}\text{As}$  in present case). The QW depths from  $E_c$  and  $E_v$  are approximately 0.28 eV and 0.16 eV respectively. Effective mass  $m_e^*$  of a conduction electron in GaAs is approximately  $0.07m_e$  where  $m_e$  is the electron mass in vacuum. Calculate the first two electron energy levels for a quantum well of thickness 10 nm. What is the hole energy in the QW above  $E_v$  of GaAs, if the hole effective mass  $m_h^* \approx 0.50m_e$ ? What is the change in the emission wavelength with respect to bulk GaAs, for which  $E_g = 1.42$  eV? Assume infinite QW depths for the calculations.

### Solution

As we saw in Ch3 (Section 3.12), the electron energy levels in the QW are with respect to the CB edge  $E_c$  in GaAs. Suppose that  $\varepsilon_n$  is the electron energy with respect to  $E_c$  in GaAs, or  $\varepsilon_n = E_n - E_c$  in Figure 4.40(b). Then, the energy of an electron in a one-dimensional infinite potential energy well is

$$\varepsilon_n = \frac{h^2 n^2}{8m_e^* d^2} = \frac{(6.626 \times 10^{-34})^2 (1)^2}{8(0.07 \times 9.1 \times 10^{-31})(10 \times 10^{-9})^2} \text{ or } 0.0538 \text{ eV}$$

where  $n$  is a quantum number, 1, 2, ..., and we have used  $d = 10 \times 10^{-9} \text{ m}$ ,  $m_e^* = 0.07m_e$  and  $n = 1$  to find  $\varepsilon_1 = 0.054 \text{ eV}$ . The next level from the same calculation with  $n = 2$  is  $\varepsilon_2 = 0.215 \text{ eV}$ .

The hole energy levels below  $E_v$  in 4.40(b) are given by

$$\varepsilon_{n'} = \frac{h^2 n'^2}{8m_h^* d^2}$$



## EXAMPLE: A GaAs quantum well

### Solution (continued)

where  $n'$  is the quantum number for the hole energy levels above  $E_v$ . Using  $d = 10 \times 10^{-9} \text{ m}$ ,  $m_h^* \approx 0.5 m_e$  and  $n' = 1$ , we find,  $\varepsilon'_1 = \mathbf{0.0075 \text{ eV}}$ .

The wavelength of emission from bulk GaAs with  $E_g = 1.42 \text{ eV}$  is

$$\lambda_g = \frac{hc}{E_g} = \frac{(6.626 \times 10^{-34})(3 \times 10^8)}{(1.42)(1.602 \times 10^{-19})} = \frac{874 \times 10^{-9} \text{ m}}{1.602 \times 10^{-19}} = 874 \text{ nm}$$

In the case of QWs, we must obey the selection rule that the radiative transition must have  $\Delta n = n' - n = 0$ . Thus, the radiative transition is from  $\varepsilon_1$  to  $\varepsilon'_1$  so that the emitted wavelength is,

$$\begin{aligned} \lambda_{\text{QW}} &= \frac{hc}{E_g + \varepsilon_1 + \varepsilon'_1} = \frac{(6.626 \times 10^{-34})(3 \times 10^8)}{(1.42 + 0.0538 + 0.0075)(1.602 \times 10^{-19})} \\ &= 838 \times 10^{-9} \text{ m} \quad (838 \text{ nm}) \end{aligned}$$

The difference is  $\lambda_g - \lambda_{\text{QW}} = 36 \text{ nm}$ . We note that we assumed an infinite PE well. If we actually solve the problem properly by using a finite well depth, then we would find  $\varepsilon_1 \approx 0.031 \text{ eV}$ ,  $\varepsilon_2 \approx 0.121 \text{ eV}$ ,  $\varepsilon'_1 \approx 0.007 \text{ eV}$ . The emitted photon wavelength is 848 nm and  $\lambda_g - \lambda_{\text{QW}} = 26 \text{ nm}$



# Elementary Laser Characteristics

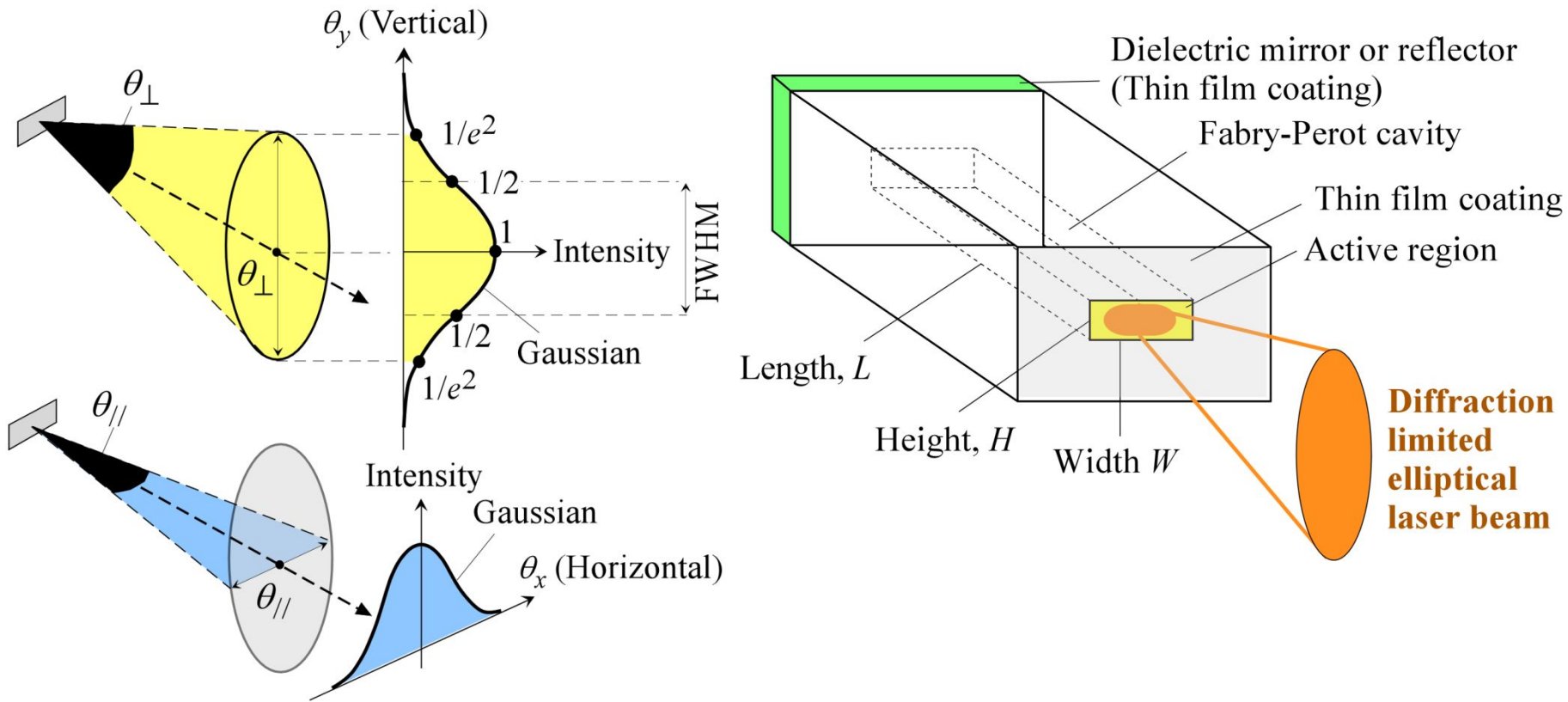

LEFT: The laser cavity definitions and the output laser beam characteristics.  
RIGHT: Laser diode output beam astigmatism. The beam is elliptical, and is characterized by two angles  $\theta_{\perp}$  and  $\theta_{\parallel}$ .

# Elementary Laser Characteristics

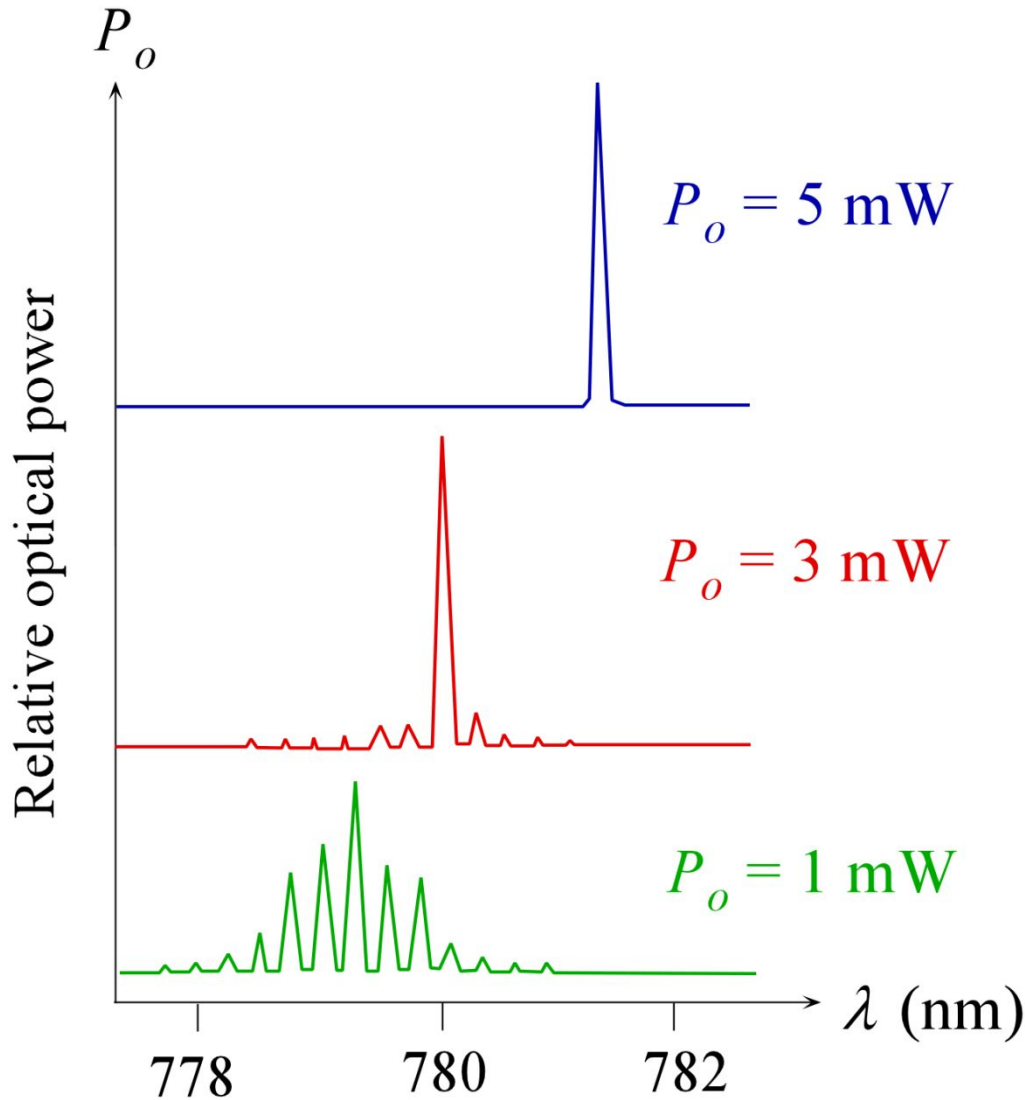

Output spectra of lasing emission from an index guided edge emitting LD. At sufficiently high diode currents corresponding to high optical power, the operation becomes single mode. (Note: Relative power scale applies to each spectrum individually and not between spectra.)

# Elementary Laser Characteristics

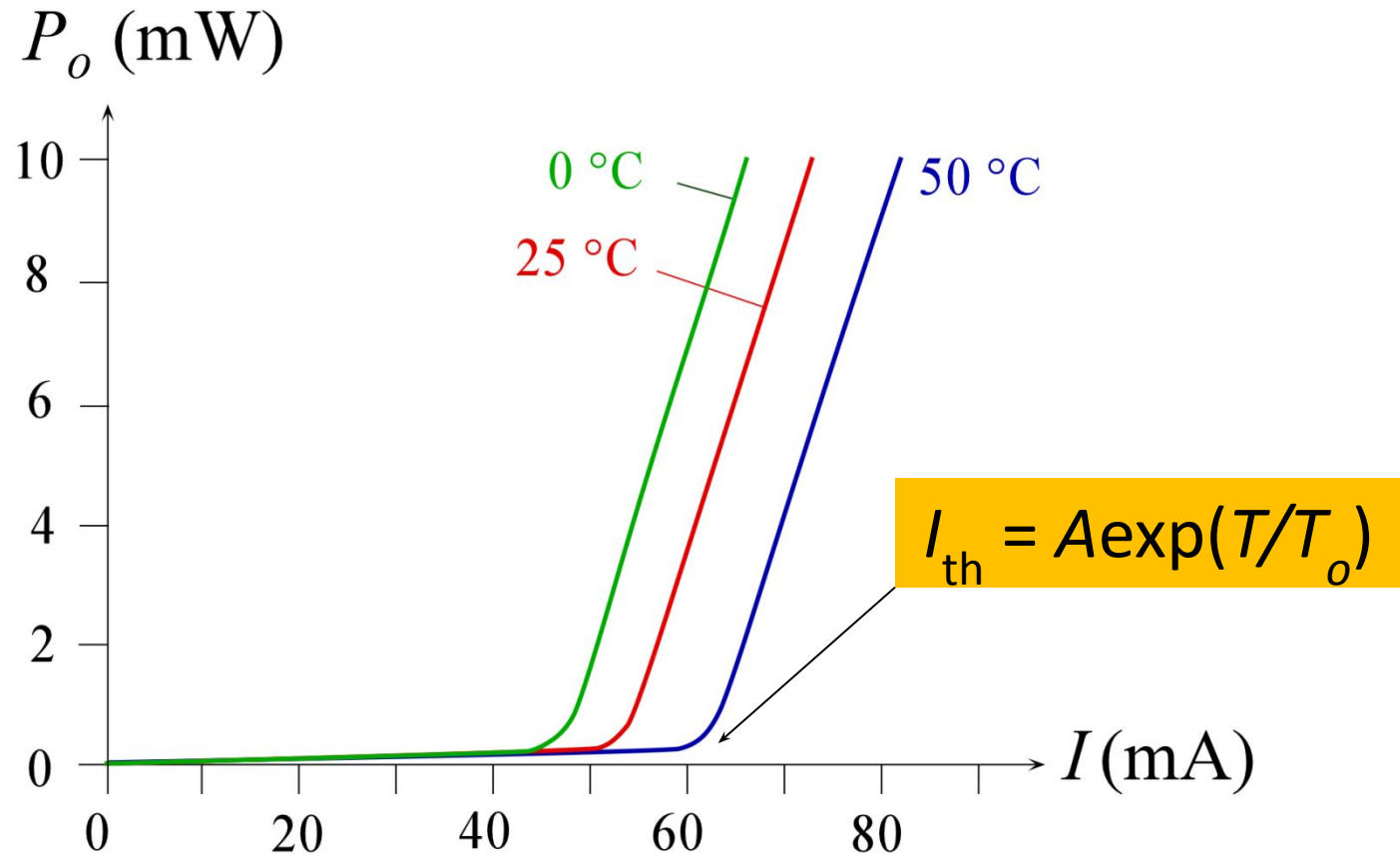

Output optical power vs. diode current at three different temperatures. The threshold current shifts to higher temperatures.

# Elementary Laser Characteristics

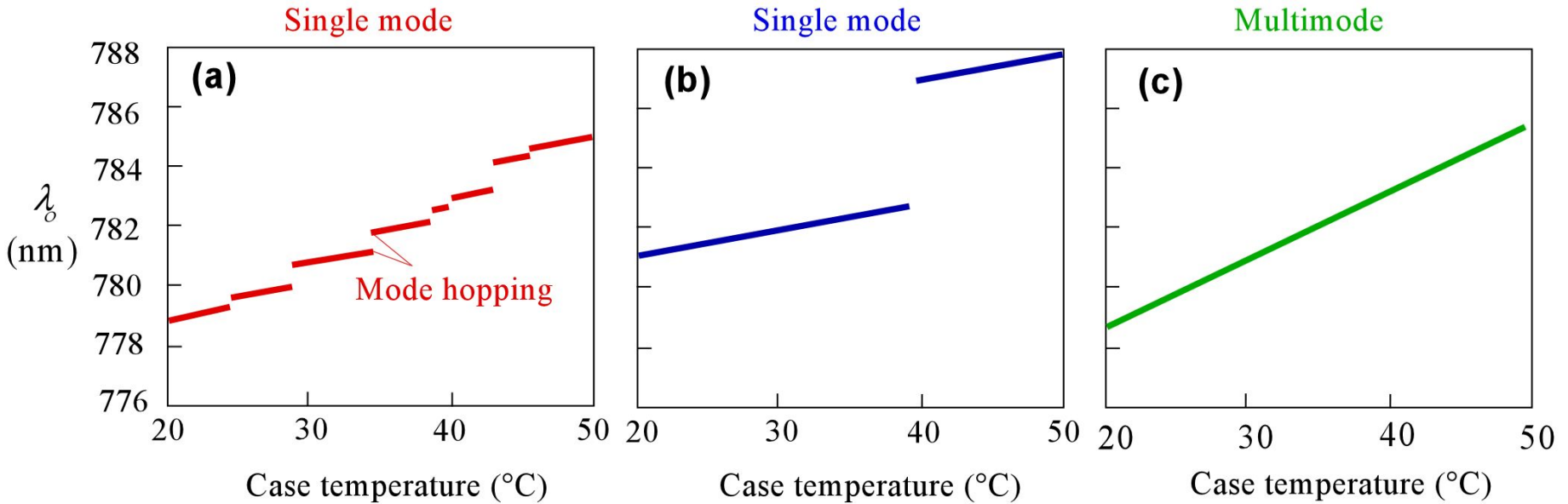

Peak wavelength  $\lambda_0$  vs. case temperature characteristics. (a) Mode hops in the output spectrum of a single mode LD. (b) Restricted mode hops and none over the temperature range of interest (20 – 40 °C ). (c) Output spectrum from a multimode LD.



## EXAMPLE: Laser output wavelength variation with temperature

The refractive index  $n$  of GaAs is approximately 3.6 and it has a temperature dependence  $d n/dT \approx 2.0 \times 10^{-4} \text{ K}^{-1}$ . Estimate the change in the emitted wavelength at around 870 nm per degree change in the temperature for a given mode.

### Solution

Consider a particular given mode with wavelength  $\lambda_m$ ,  $m \left( \frac{\lambda_m}{2n} \right) = L$   
If we differentiate  $\lambda_m$  with respect to temperature,

$$\frac{d\lambda_m}{dT} = \frac{d}{dT} \left[ \frac{2}{m} nL \right] \approx \frac{2L}{m} \frac{dn}{dT}$$

where we neglected the change in the cavity length with temperature.

Substituting for  $L/m$  in terms of  $\lambda_m$ ,

$$\frac{d\lambda_m}{dT} \approx \frac{\lambda_m}{n} \frac{dn}{dT} = \frac{870 \text{ nm}}{3.6} (2 \times 10^{-4} \text{ K}^{-1})$$

Note that we have used  $n$  for a passive cavity whereas  $n$  above should be the effective refractive index of the active cavity which will also depend on the optical gain of the medium, and hence its temperature dependence is likely to be somewhat higher than the  $d n/dT$  value we used. It is left as an exercise to show that the changes in  $\lambda_m$  due to the expansion of the cavity length with temperature is much less than that arising from  $d n/dT$ . The linear expansion coefficient of GaAs is  $6 \times 10^{-6} \text{ K}^{-1}$ .



# Laser Diode Efficiencies

## Slope Efficiency

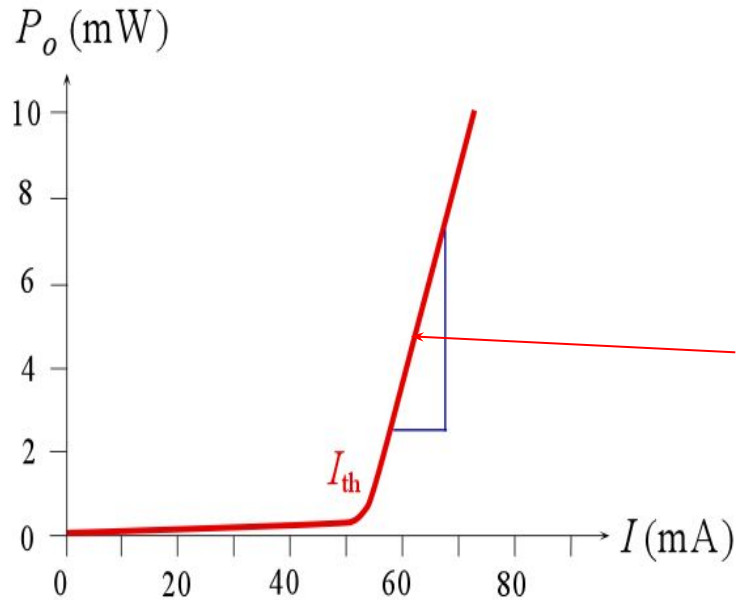

$$\eta_{\text{slope}} = \left( \frac{\Delta P_o}{\Delta I} \right)_{\text{above threshold}} \approx \frac{P_o}{I - I_{th}}$$

$$\eta_{\text{slope}} = \frac{\text{Increase in optical output power}}{\text{Increase in input current above threshold}}$$





# Laser Diode Efficiencies

## External Quantum Efficiency

$$\eta_{\text{EQE}} = \frac{\text{Number of output photons from the diode per unit second}}{\text{Number of injected electrons into the diode per unit second}}$$

$$\eta_{\text{EQE}} = \frac{P_o / h\nu}{I / e} \approx \frac{eP_o}{E_g I}$$



# Laser Diode Efficiencies

## External Differential Quantum Efficiency

$$\eta_{\text{EDQE}} = \frac{\text{Increase in number of output photons from diode per unit second}}{\text{Increase in number of injected electrons into diode per unit second}}$$

$$\eta_{\text{EDQE}} = \frac{\Delta P_o / h\nu}{\Delta I / e} = \eta_{\text{slope}} \frac{e}{h\nu} \approx \left( \frac{e}{E_g} \right) \frac{P_o}{I - I_{\text{th}}}$$



# Laser Diode Efficiencies

## Internal Quantum Efficiency

$$\eta_{\text{IDQE}} = \frac{\text{Number of photons generated internally per unit second}}{\text{Number of injected electrons into diode per unit second}}$$

$$\eta_{\text{IQE}} = \frac{1/\tau_r}{1/\tau_r + 1/\tau_{nr}}$$

$\tau_{nr}$  = Nonradiative recombination time

$\tau_r$  = Radiative recombination time



# Laser Diode Efficiencies

## Internal Differential Quantum Efficiency

$$\eta_{\text{IDQE}} = \frac{\text{Increase in number of photons generated internally per unit second}}{\text{Increase in number of injected electrons into diode per unit second}}$$

If the current increases by  $\Delta I$  above threshold, increase in the injected electrons is  $\Delta I/e$

**The increase in the number of photons generated *internally* is then**

$$\eta_{\text{IDQE}} \times \Delta I/e$$



# Laser Diode Efficiencies

Extraction efficiency

=

(Loss from the exit cavity end)  
/ (Total loss)

$$\eta_{\text{EE}} = (1/2L)\ln(1/R_1) / \alpha_t$$



# Laser Diode Efficiencies

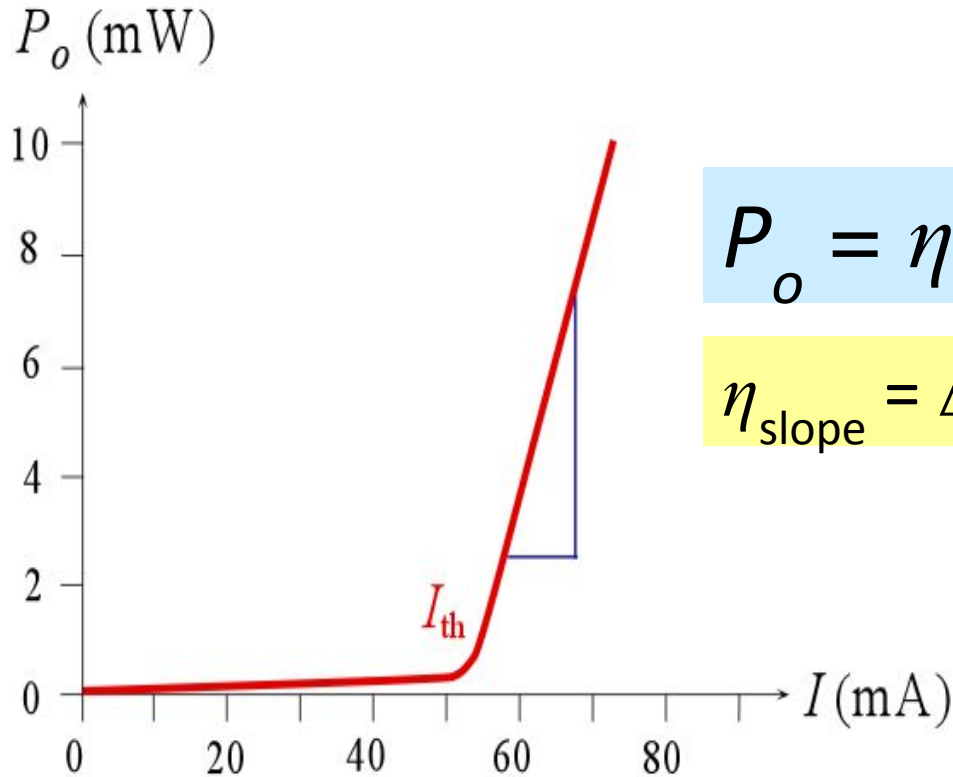

$$P_o = \eta_{EE} \eta_{IDQE} h\nu (I - I_{th}) / e$$

$$\eta_{\text{slope}} = \Delta P_o / \Delta I = \eta_{EE} \eta_{IDQE} h\nu / e$$

$$\begin{aligned} \eta_{EDQE} &= (\Delta P_o / h\nu) / (\Delta I / e) \\ &= (P_o / h\nu) / [(I - I_{th}) / e] = \eta_{EE} \eta_{IDQE} \end{aligned}$$



# Laser Diode Efficiencies

## Power Conversion Efficiency

$$\eta_{\text{PCE}} = \frac{\text{Optical output power}}{\text{Electrical input power}} = \frac{P_o}{IV} \approx \eta_{\text{EQE}} \left( \frac{E_g}{eV} \right)$$

$$\eta_{\text{PCE}} = \frac{P_o}{IV} \approx \eta_{\text{EQE}} \left( \frac{E_g}{eV} \right)$$



# Laser Diode Efficiencies

Typical characteristics for a few selected red and violet commercial laser diodes. All LDs are MQW structures and have FP cavities. Violet lasers are based on InGaN/GaN MQW, and red LEDs use mainly AlGaInP/GaInP MQW.

LD	$P_o$ (mW)	$\lambda$ (nm)	$I_{th}$ (mA)	$I$ (mA)	$V$ (V)	$\theta_{\perp}$	$\theta_{//}$	$\eta_{slope}$ (mW/mA)	$\eta_{PCE}$ %
Red	500	670	400	700	2.4	21°	10°	1.0	30
Red	100	660	75	180	2.5	18°	9°	1.0	22
Red	50	660	60	115	2.3	17°	10°	0.90	19
Red	10	639	30	40	2.3	21°	8°	1.0	11
Violet	400	405	160	390	5.0	45°	15°	1.7	21
Violet	120	405	45	120	5.0	17°	8°	1.6	20
Violet	10	405	26	35	4.8	19°	8.5°	1.1	6.0





# Laser Diode Efficiencies

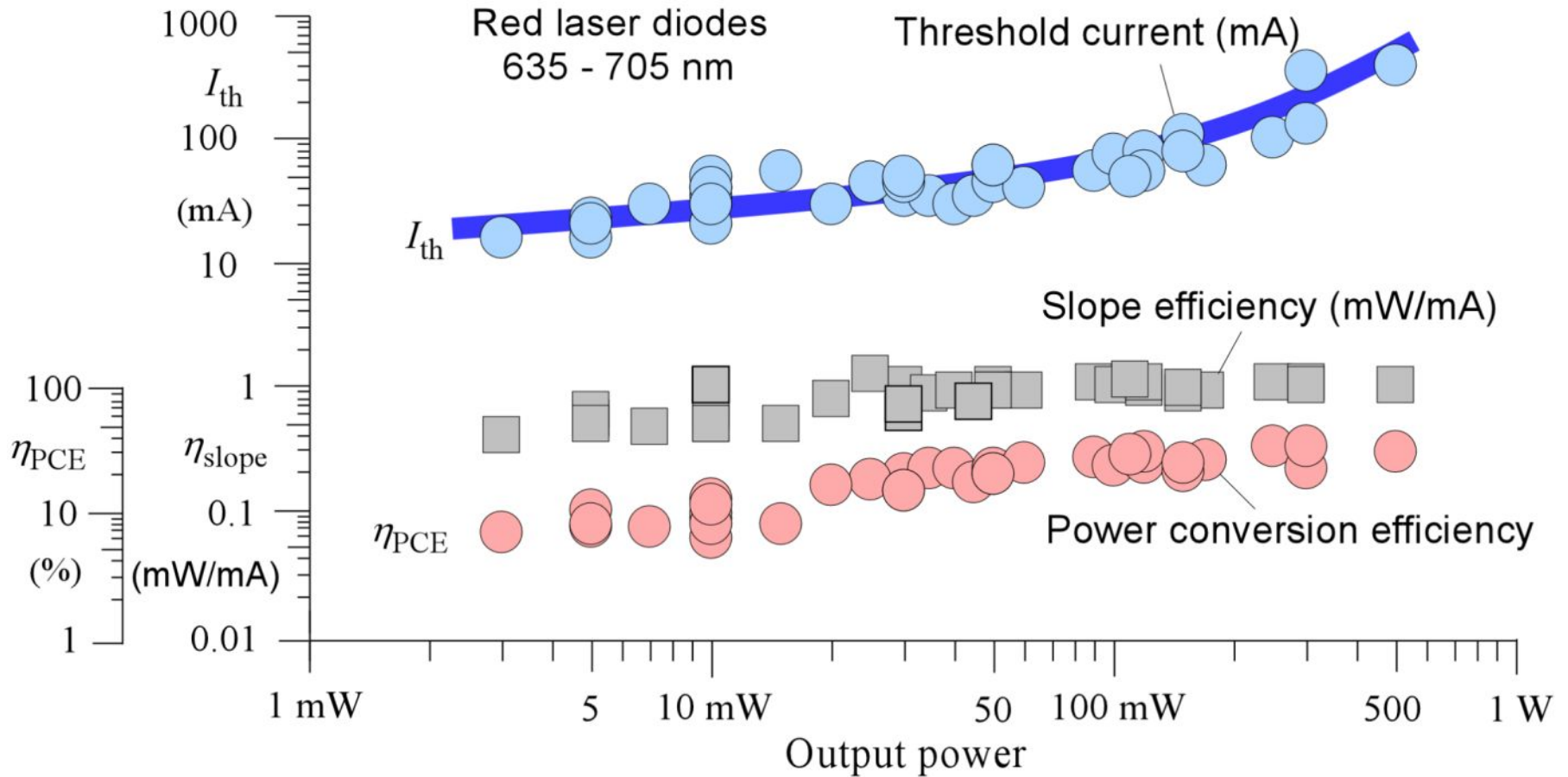

Typical values for the threshold current  $I_{th}$ , slope efficiency ( $\eta_{slope}$ ) and power conversion efficiency ( $\eta_{PCE}$ ) for 36 commercial red LDs with different optical output powers from 3 mW – 500 mW.



## EXAMPLE: Laser diode efficiencies for a sky blue LD

Consider a 60 mW blue LD (Nichia SkyBlue NDS4113), emitting at a peak wavelength of 488 nm. The threshold current is 30 mA. At a forward current of 100 mA and a voltage of 5.6 V, the output power is 60 mW. Find the slope efficiency, PCE, EQE and EDQE.

### Solution

From the definition in Eq. (4.12.2),

$$\begin{aligned}\eta_{\text{slope}} &= P_o / (I - I_{\text{th}}) \\ &= (60 \text{ mW}) / (100 - 30 \text{ mA}) = \mathbf{0.86 \text{ mW/mA}^{-1}}\end{aligned}$$

From Eq. (4.12.8), PCE is

$$\begin{aligned}\eta_{\text{PCE}} &= P_o / IV \\ &= (60 \text{ mW}) / [(100 \text{ mA})(5.6 \text{ V})] = \mathbf{0.11 \text{ or } 11\%}\end{aligned}$$

We can find the EQE from Eq. (4.12.3) but we need  $h\nu$ , which is  $hc/\lambda$ . In eV,

$$\begin{aligned}h\nu \text{ (eV)} &= 1.24 / \lambda \text{ (\mu m)} \\ &= 1.24 / 0.488 = 2.54 \text{ eV}\end{aligned}$$

EQE is given by Eq. (4.12.3)

$$\begin{aligned}\eta_{\text{EQE}} &= (P_o / h\nu) / (I / e) \\ &= [(60 \times 10^{-3}) / (2.54 \times 1.6 \times 10^{-19})] / [(100 \times 10^{-3}) / (1.6 \times 10^{-19})] =\end{aligned}$$

**0.24 or 24%**



## EXAMPLE: Laser diode efficiencies for a sky blue LD

### Solution (continued)

Similarly,  $\eta_{\text{EDQE}}$  is given by Eq. (4.12.4b) above threshold,

$$\eta_{\text{EDQE}} = (\Delta P_o / h\nu) / (\Delta I / e) \approx (P_o / h\nu) / [(I - I_{\text{th}}) / e]$$

$$= [(60 \times 10^{-3}) / (2.54 \times 1.6 \times 10^{-19})] / [(100 \times 10^{-3} - 30 \times 10^{-3}) / 1.6 \times 10^{-19}]$$

$$= \mathbf{0.34 \text{ or } 34\%}$$

The EDQE is higher than the EQE because most injected electrons above  $I_{\text{th}}$  are used in stimulated recombinations. EQE gauges the total conversion efficiency from all the injected electrons brought by the current to coherent output photons. But, a portion of the current is used in pumping the gain medium.



## EXAMPLE: Laser diode efficiencies

Consider an InGaAs FP semiconductor laser diode that emits CW radiation at 1310 nm. The cavity length ( $L$ ) is 200  $\mu\text{m}$ . The internal loss coefficient  $\alpha_s = 20 \text{ cm}^{-1}$ ,  $R_1 = R_3 \approx 0.33$  (cleaved ends). Assume that internal differential quantum efficiency, IDQE, is close to 1. The threshold current is 5 mA. What is the output power  $P_o$  at  $I = 20 \text{ mA}$ ? The forward voltage is about 1.3 V. What is the EDQE and conversion efficiency?

### Solution

From the definition of IDQE in Eq. (4.12.6), the number of internal coherent photons generated per second above threshold is  $\eta_{\text{IDQE}}(I - I_{\text{th}})/e$ . Thus,

$$\text{Internal optical power generated} = h\nu \times \eta_{\text{IDQE}}(I - I_{\text{th}})/e$$

The extraction efficiency  $\eta_{\text{EE}}$  then couples a portion of this optical power into the output radiation. The output power  $P_o$  is then  $\eta_{\text{EE}} \times h\nu \times \eta_{\text{IDQE}}(I - I_{\text{th}})/e$ . Thus,

$$P_o = \eta_{\text{EE}} \eta_{\text{IDQE}} h\nu (I - I_{\text{th}})/e \quad \text{Output power vs current} \quad (4.12.9)$$

The slope efficiency from Eq.(4.12.2) is

$$\eta_{\text{slope}} = \Delta P_o / \Delta I = \eta_{\text{EE}} \eta_{\text{IDQE}} (h\nu/e) \quad \text{Slope efficiency} \quad (4.12.10)$$



### EXAMPLE .3: Laser diode efficiencies

#### Solution (continued)

Further, from the definition of EDQE and Eq.(4.12.9) is

$$\eta_{\text{EDQE}} = (\Delta P_o / h\nu) / (\Delta I / e) = (P_o / h\nu) / [(I - I_{\text{th}}) / e] = \eta_{\text{EE}} \eta_{\text{IDQE}}$$

*External differential quantum efficiency*      (4.12.11)

We can now calculate the quantities needed. The total loss coefficient is

$$\alpha_t = \alpha_s + (1/2L) \ln (1 / R_1 R_2)$$

$$= 2000 + (2 \times 200 \times 10^{-6})^{-1} \ln(0.33 \times 0.33)^{-1} = 7543 \text{ m}^{-1}$$

The extraction efficiency is

$$\eta_{\text{EE}} = (1/2L) \ln (1/R_1) / \alpha_t = (2 \times 200 \times 10^{-6})^{-1} \ln(1/0.33) / (7543)$$

**= 0.37 or 37%**

## EXAMPLE: Laser diode efficiencies

### Solution (continued)



Thus, using  $I = 20$  mA in Eq. (4.12.9),

$$P_o = (0.37)(1)[(6.62 \times 10^{-34})(3 \times 10^8)/(1310 \times 10^{-9})][(0.02 - 0.005) / (1.6 \times 10^{-19})] = \mathbf{5.2 \text{ mW}}$$

The slope efficiency from Eq. (4.12.10) is

$$\eta_{\text{slope}} = \Delta P_o / \Delta I = (5.2 \text{ mW} - 0) / (20 \text{ mA} - 5 \text{ mA}) = \mathbf{0.35 \text{ mW mA}^{-1}}$$

The EDQE from Eq. (4.12.11) is

$$\eta_{\text{EDQE}} = \eta_{\text{EE}} \eta_{\text{IDQE}} = \mathbf{0.37 \text{ or } 37\%}$$

$$\begin{aligned} \text{The power conversion efficiency } \eta_{\text{PCE}} &= P_o / IV \\ &= 5.2 \text{ mW} / (20 \text{ mA} \times 1.3 \text{ V}) \\ &= \mathbf{0.20 \text{ or } 20\%} \end{aligned}$$

# Laser Diode Equation

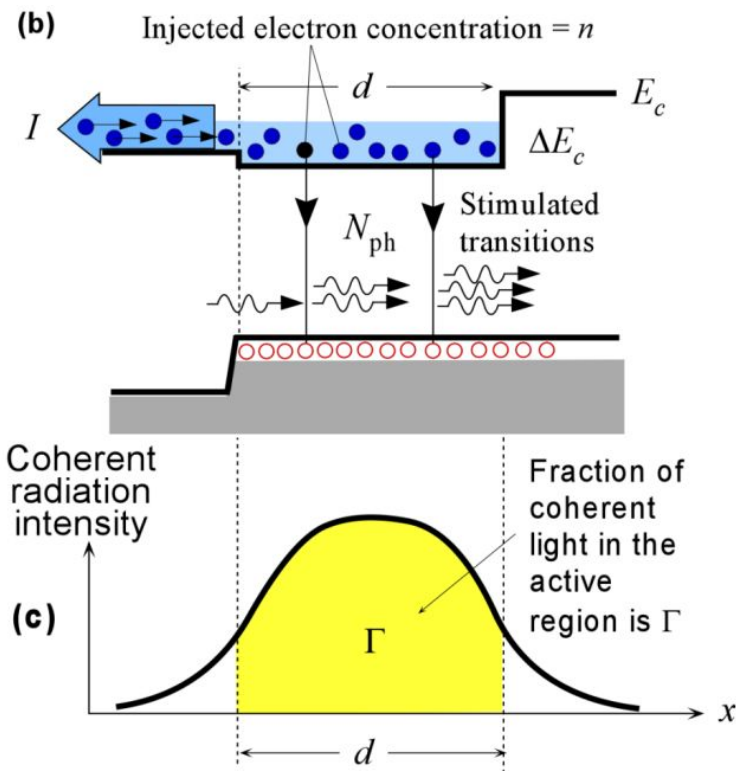
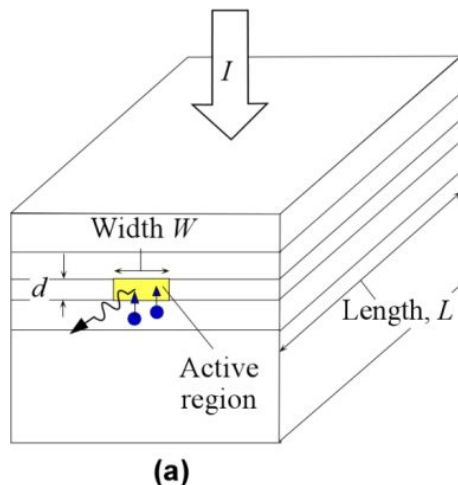

A highly simplified and idealized description of a semiconductor laser diode for deriving the LD equation. (a) The heterostructure laser diode structure. (b) The current  $I$  injects electrons in the conduction band, and these electrons recombine radiatively with the holes in the active region. (c) The coherent radiation intensity across the device; only a fraction  $\Gamma$  is within the active region where there is optical gain. (d) Injected electron concentration  $n$  and coherent radiation output power  $P_o$  vs. diode current  $I$ . The current represents the pump rate.

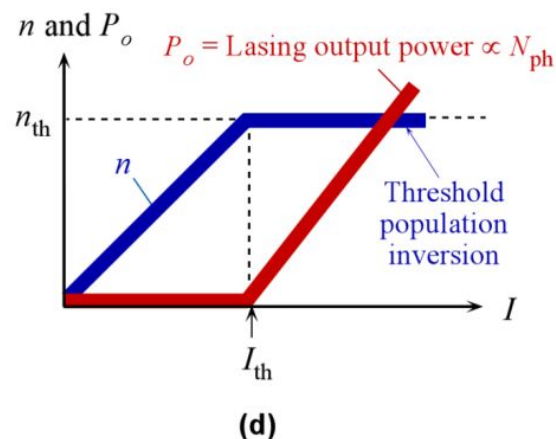



# Laser Diode Equation

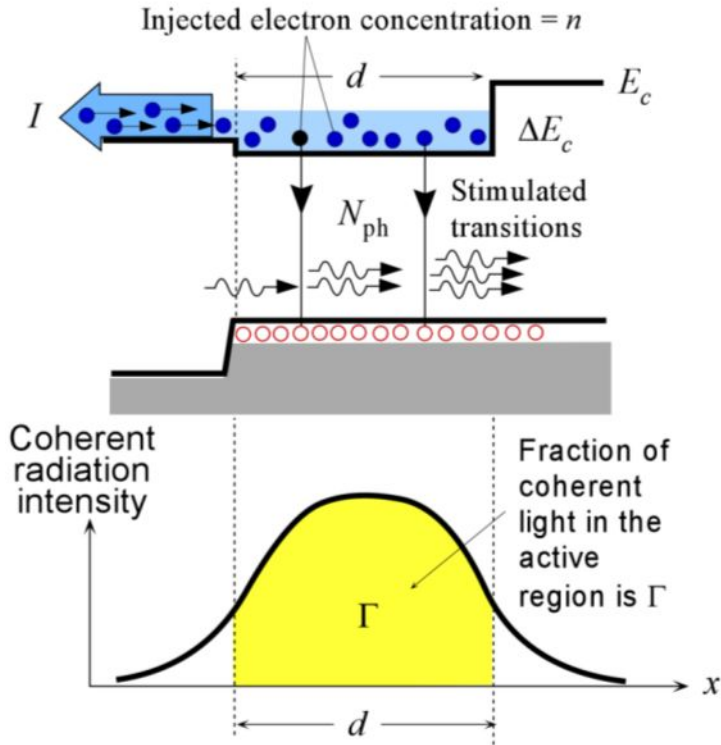

$$\frac{I}{eLWd} = \frac{n}{\tau_r} + CnN_{ph}$$

Radiative lifetime

Rate of electron injection by current  $I$   
 = Rate of spontaneous emissions  
 + Rate of stimulated emissions

$$\frac{N_{ph}}{\tau_{ph}} = CnN_{ph}$$

Rate of coherent photon loss in the cavity  
 = Rate of stimulated emissions

Photon cavity lifetime





# Laser Diode Equation

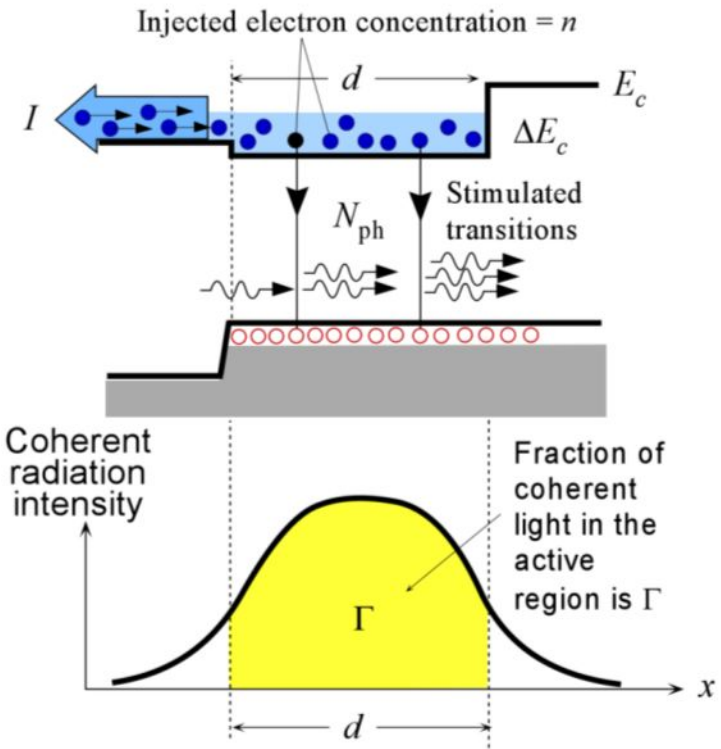

$$\frac{I_{th}}{eLWd} \approx \frac{n_{th}}{\tau_r} \quad \text{Threshold}$$

$$n_{th} = \frac{1}{C\tau_{ph}} \quad \text{Threshold}$$

Substitute back into steady state rate equation

$$\frac{I}{eLWd} = \frac{n_{th}}{\tau_r} + Cn_{th}N_{ph} \quad \Rightarrow \quad N_{ph} = \frac{\tau_{ph}}{eLWd} (I - I_{th})$$



# Laser Diode Equation

$$N_{\text{ph}} = \frac{\tau_{\text{ph}}}{eLWd} (I - I_{\text{th}})$$

$$P_o = \frac{(\frac{1}{2} N_{\text{ph}})(\text{Cavity Volume})(\text{Photon energy})}{\Delta t} (1 - R)$$

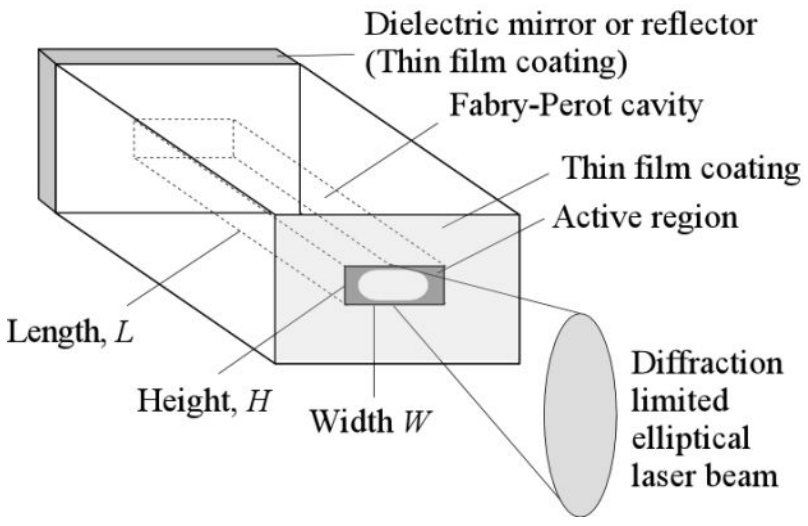

$$P_o = \left[ \frac{hc^2 \tau_{\text{ph}} (1 - R)}{2en\lambda L} \right] (I - I_{\text{th}})$$

$$I_o = \left[ \frac{hc^2 \tau_{\text{ph}} (1 - R)}{2en\lambda d} \right] (J - J_{\text{th}})$$

Light intensity =  $P_o / A$



# Threshold Gain

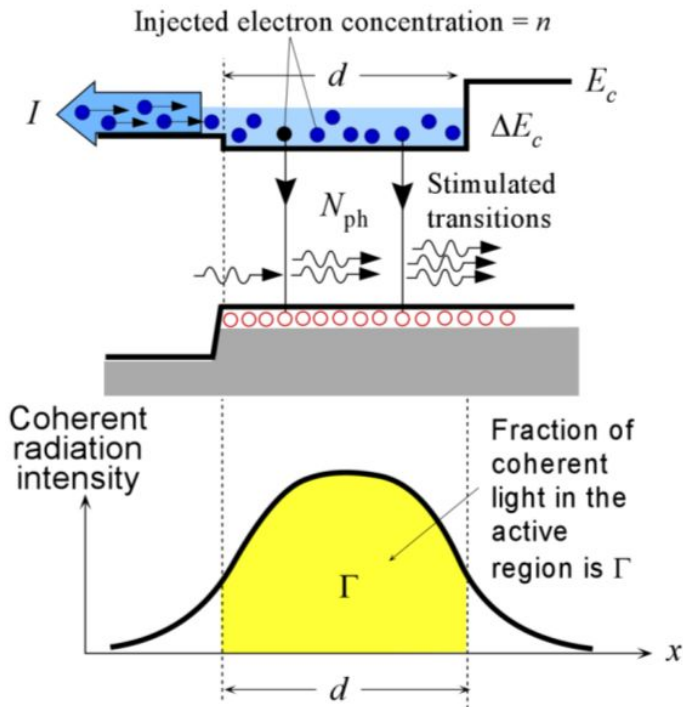

$$\Gamma g_{th} = \alpha_t = \alpha_s + \frac{1}{2L} \ln \left( \frac{1}{R_1 R_2} \right)$$

$\Gamma$  = Fraction of the coherent optical radiation within the active region

The gain  $g$  works on the radiation within the cavity, which means that we must multiply  $g$  with  $\Gamma$  to account for less than perfect optical confinement

# Optical Gain Curve

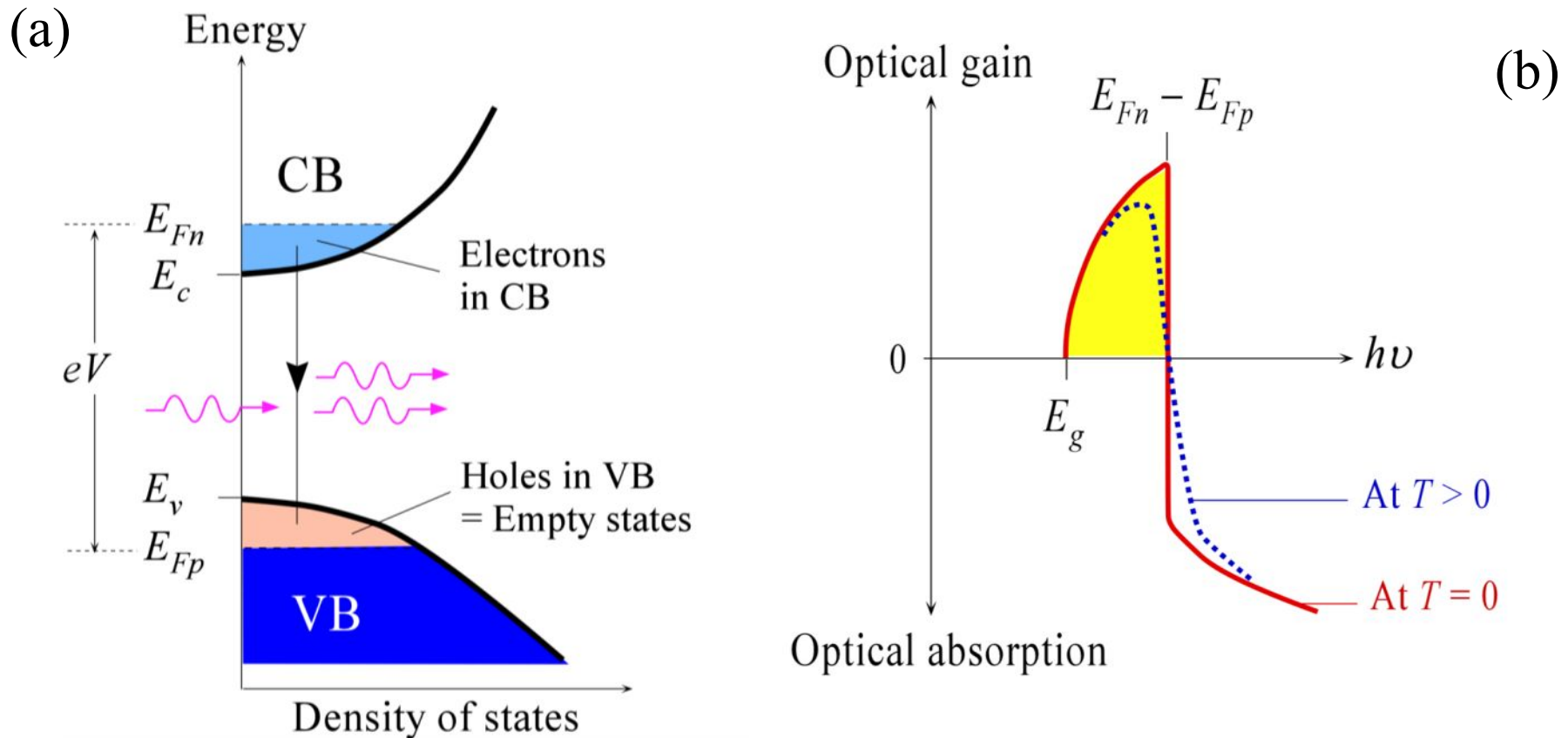

(a) The density of states and energy distribution of electrons and holes in the conduction and valence bands respectively at  $T > 0$  in the SCL under forward bias such that  $E_{Fn} - E_{Fp} > E_g$ . Holes in the VB are empty states. (b) Gain vs. photon energy ( $h\nu$ ).



# Optical Gain Curve

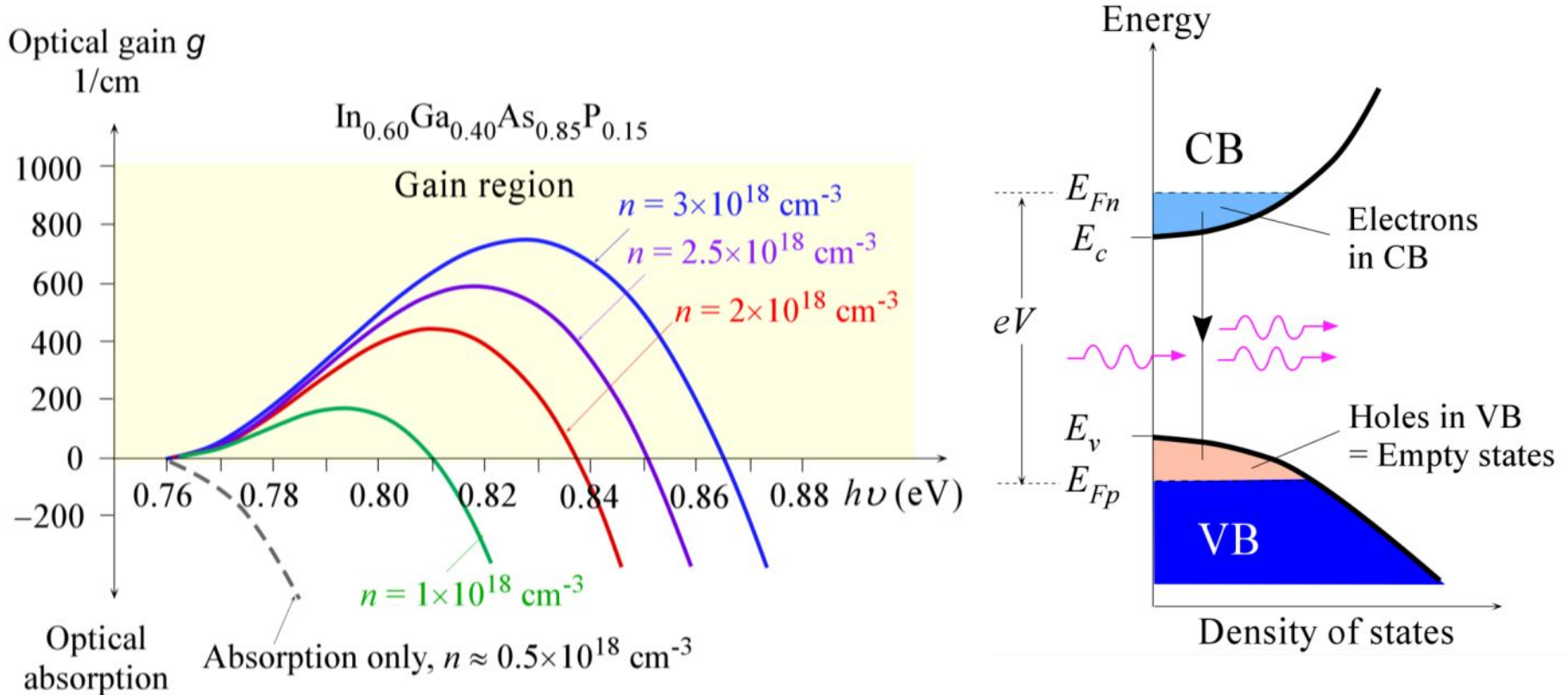

Optical gain  $g$  vs. photon energy for an InGaAsP active layer (in a 1500 nm LD) as a function of injected carrier concentration  $n$  from  $1 \times 10^{18}$  to  $3 \times 10^{18} \text{ cm}^{-3}$ . (The model described in Leuthold *et al*, *J. Appl. Phys.*, 87, 618, 2000 was used to find the gain spectra at different carrier concentrations.) (Data combined from J. Singh, *Electronic and Optoelectronic Properties of Semiconductor Structures*, Cambridge University Press, 203, p390; N.K. Dutta, *J. Appl. Phys.*, 51, 6095, 1980; J. Leuthold *et al*, *J. Appl. Phys.*, 87, 618, 2000.)



# Optical Gain Curve

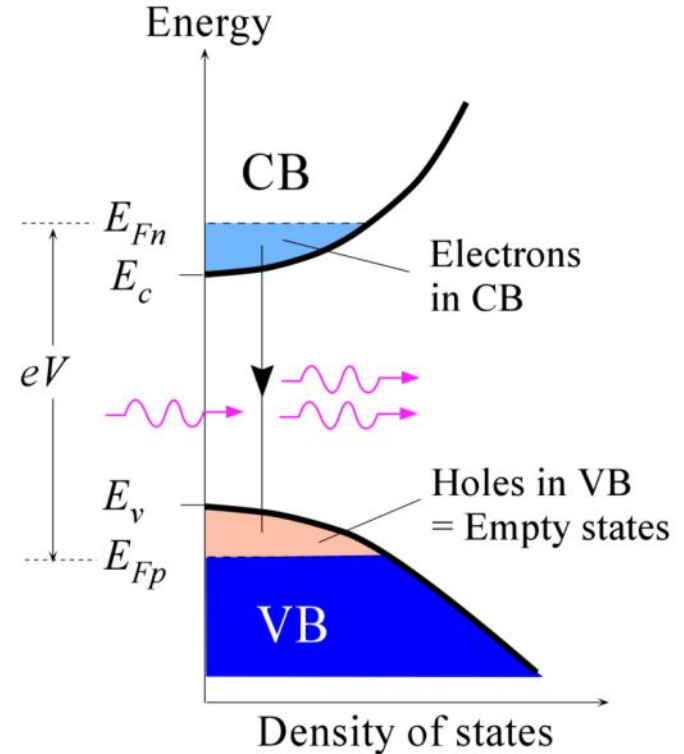
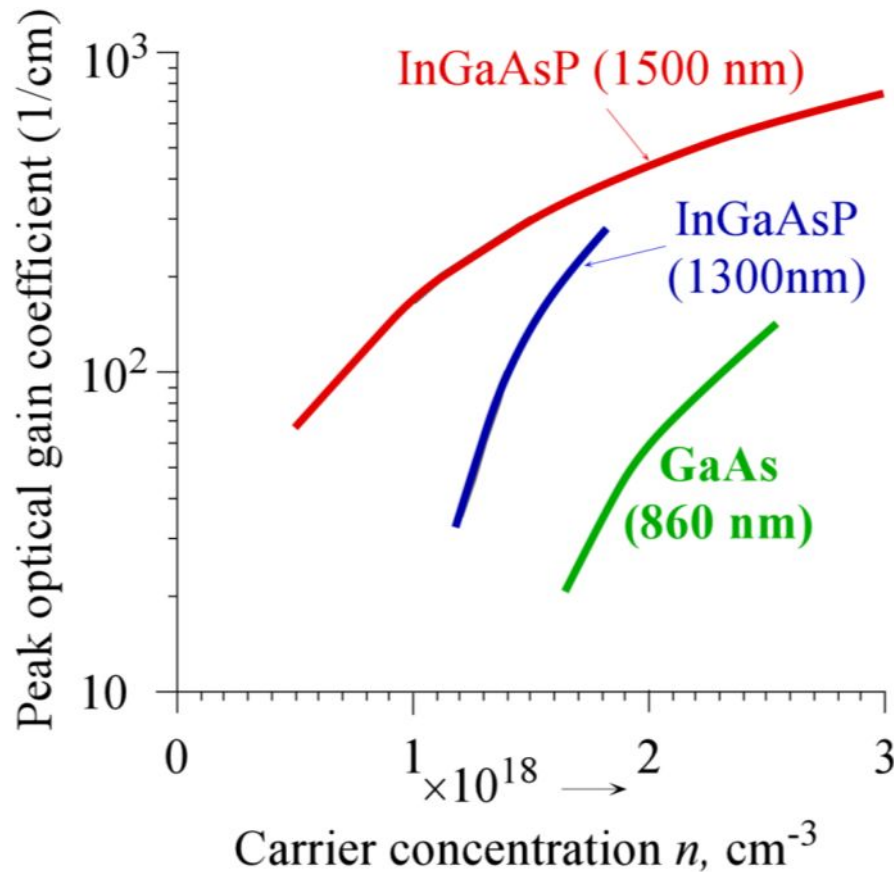

The dependence of the peak gain coefficient (maximum  $g$ ) on the injected carrier concentration  $n$  for GaAs (860 nm),  $\text{In}_{0.72}\text{Ga}_{0.28}\text{As}_{0.6}\text{P}_{0.4}$  (1300 nm), and  $\text{In}_{0.60}\text{Ga}_{0.40}\text{As}_{0.85}\text{P}_{0.15}$  (1500 nm) active layers. (Data combined from J. Singh, *Electronic and Optoelectronic Properties of Semiconductor Structures*, Cambridge University Press, 203, p390; N.K. Dutta, *J. Appl. Phys.*, 51, 6095, 1980; J. Leuthold *et al.*, *J. Appl. Phys.*, 87, 618, 2000.)



## EXAMPLE: Threshold current and optical output power from a Fabry-Perot (FP) heterostructure laser diode

Consider GaAs DH laser diode that lases at 860 nm. It has an active layer (cavity) length  $L$  of 250  $\mu\text{m}$ . The active layer thickness  $d$  is 0.15  $\mu\text{m}$  and the width  $W$  is 5  $\mu\text{m}$ . The refractive index is 3.6, and the attenuation coefficient  $\alpha_s$  inside the cavity is  $10^3 \text{ m}^{-1}$ . The required threshold gain  $g_{th}$  corresponds to a threshold carrier concentration  $n_{th} \approx 2 \times 10^{18} \text{ cm}^{-3}$ . The radiative lifetime  $\tau_r$  in the active region can be found (at least approximately) by using  $\tau_r = 1/Bn_{th}$ , where  $B$  is the direct recombination coefficient, and assuming strong injection as will be the case for laser diodes [see Eq. (3.8.7) in Chapter 3]. For GaAs,  $B \approx 2 \times 10^{-16} \text{ m}^3 \text{ s}^{-1}$ . What is the threshold current density and threshold current? Find the output optical power at  $I = 1.5I_{th}$ , and the external slope efficiency  $\eta_{slope}$ . How would  $\Gamma = 0.5$  affect the calculations?

### Solution

The reflectances at the each end are the same (we assume no other thin film coating on the ends of the cavity) so that  $R = (n-1)^2 / (n+1)^2 = 0.32$ . The total attenuation coefficient  $\alpha_t$  and hence the threshold gain  $g_{th}$ , assuming  $\Gamma = 1$  in Eq. (4.13.9), is

$$g_{th} = \alpha_t = (10 \text{ cm}^{-1}) + \frac{1}{(250 \times 10^{-4} \text{ cm})} \ln \left[ \frac{1}{(0.32)(0.32)} \right]$$

From Figure 4.48(b), at this gain of 56  $\text{cm}^{-1}$ ,  $n_{th} \approx (2 \times 10^{18} \text{ cm}^{-3})$ . This is the threshold carrier concentration that gives the right gain under ideal optical confinement, with  $\Gamma = 1$ .

## EXAMPLE: Threshold current and optical output power from a Fabry-Perot (FP) heterostructure laser diode

### Solution (continued)

The radiative lifetime  $\tau_r = 1/Bn_{th} = 1/[2 \times 10^{-16} \text{ m}^3 \text{ s}^{-1}](2 \times 10^{24} \text{ m}^{-3}) = \mathbf{2.5 \text{ ns}}$

Since  $J = I/WL$ , the threshold current density from Eq. (4.13.4) is

$$\begin{aligned} &= J_{th} = \frac{n_{th}ed}{\tau_r} = \frac{(2 \times 10^{24} \text{ m}^{-3})(1.6 \times 10^{-19} \text{ C})(0.15 \times 10^{-6} \text{ m})}{(2.5 \times 10^{-9} \text{ s})} \\ &= 1.9 \times 10^7 \text{ A m}^{-2} \text{ or } 1.9 \text{ kA cm}^{-2} \text{ or } 19 \text{ A mm}^{-2}. \end{aligned}$$

The threshold current itself is,

$$I_{th} = (WL)J_{th} = (5 \times 10^{-6} \text{ m})(250 \times 10^{-6} \text{ m})(1.9 \times 10^7 \text{ A m}^{-2}) = 0.024 \text{ A} \text{ or } \mathbf{24 \text{ mA}}$$

The photon cavity lifetime depends on  $\alpha_p$ , and is given by

$$\begin{aligned} \tau_{ph} &= n/(c\alpha_t) = 3.6 / [(3 \times 10^8 \text{ m s}^{-1})(5.56 \times 10^3 \text{ m}^{-1})] \\ &= \mathbf{2.16 \text{ ps}} \end{aligned}$$

The laser diode output power is

$$P_o = \left[ \frac{hc^2\tau_{ph}(1-R)}{2en\lambda L} \right] (I - I_{th}) = \frac{(6.626 \times 10^{-34})(3 \times 10^8)^2(2.16 \times 10^{-12})(1-0.32)}{2(1.6 \times 10^{-19})(3.6)(860 \times 10^{-9})(250 \times 10^{-6})} (I - I_{th})$$



## EXAMPLE: Threshold current and optical output power from a Fabry-Perot (FP) heterostructure laser diode

### Solution (continued)

That is  $P_o = (0.35 \text{ W A}^{-1})(I - I_{th}) = (0.35 \text{ mW mA}^{-1})(I - 24 \text{ mA})$

When  $I = 1.5I_{th} = 36 \text{ mA}$ ,

$$P_o = (0.35 \text{ mW mA}^{-1})(36 \text{ mA} - 24 \text{ mA}) = \mathbf{4.2 \text{ mW}}$$

The slope efficiency is the slope of the  $P_o$  vs.  $I$  characteristic above  $I_{th}$ ,

$$\eta_{\text{slope}} = \frac{\Delta P_o}{\Delta I} = \left[ \frac{hc^2 \tau_{\text{ph}} (1-R)}{2en\lambda L} \right]^{-1} = \mathbf{0.35 \text{ mW mA}^{-1}}$$

We can now repeat the problem say for  $\Gamma = 0.5$ , which would give  $\Gamma g_{th} = \alpha_r$ , so that  $g_{th} = 55.6 \text{ cm}^{-1} / 0.5 = 111 \text{ cm}^{-1}$ . From Figure 4.48 (b), at this gain of  $111 \text{ cm}^{-1}$ ,  $n_{th} \approx 2.5 \times 10^{18} \text{ cm}^{-3}$ . The new radiative lifetime,

$$\tau_r = 1/Bn_{th} = 1/[2.0 \times 10^{-16} \text{ m}^3 \text{ s}^{-1})(2.5 \times 10^{24} \text{ m}^{-3})] = 2.0 \text{ ns}$$

The corresponding threshold current density is

$$J_{th} = n_{th} ed/\tau_r = (2.5 \times 10^{24} \text{ m}^{-3})(1.6 \times 10^{-19} \text{ C})(0.15 \times 10^{-6} \text{ m})/(2.0 \times 10^{-9} \text{ s}) \\ = \mathbf{30 \text{ A mm}^{-2}}$$

and the corresponding threshold current  $I_{th}$  is  $\mathbf{37.5 \text{ mA}}$

## EXAMPLE: Threshold current and optical output power from a Fabry-Perot (FP) heterostructure laser diode



### Solution (continued)

#### There are several important notes to this problem

- First, the threshold concentration  $n_{th} \approx 2 \times 10^{18} \text{ cm}^{-3}$  was obtained graphically from Figure 4.48 (b) by using the  $g_{th}$  value we need.
- Second is that, at best, the calculations represent rough values since we also need to know how the mode spreads into the cladding where there is no gain but absorption and, in addition, what fraction of the current is lost to nonradiative recombination processes. We can increase  $\alpha_s$  to account for absorption in the cladding, which would result in a higher  $g_{th}$ , larger  $n_{th}$  and greater  $I_{th}$ . If  $\tau_{nr}$  is the nonradiative lifetime, we can replace  $\tau_r$  by an effective recombination time  $\tau$  such that , which means that the threshold current will again be larger. We would also need to reduce the optical output power since some of the injected electrons are now used in nonradiative transitions.
- Third, is the low slope efficiency compared with commercial LDs.  $\eta_{slope}$  depends on  $\tau_{ph}$ , the photon cavity lifetime, which can be greatly improved by using better reflectors at the cavity ends, *e.g.* , by using thin film coating on the crystal facets to increase  $R$ .

# Distributed Bragg Reflector (DBR) LDs

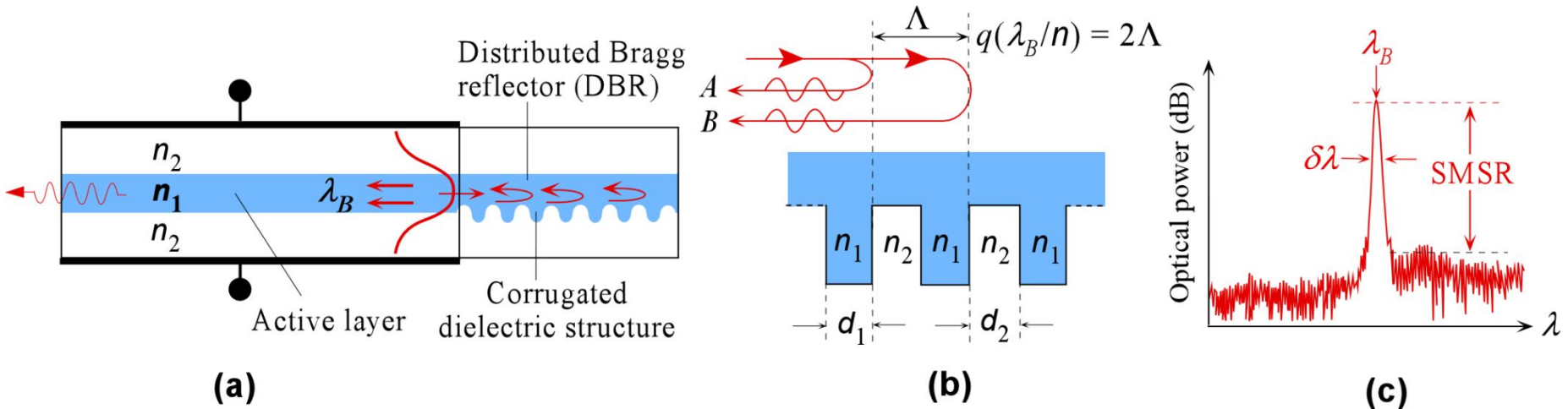

(a) The basic principle of the Distributed Bragg Reflection (DBR) laser. (b) Partially reflected waves at the corrugations can only constitute a reflected wave when the wavelength satisfies the Bragg condition. Reflected waves A and B interfere constructively when  $q(\lambda_B/n) = 2\Lambda$ . (c) Typical output spectrum. SMSR is the side mode suppression ratio.

## Distributed Feedback (DFB) LDs

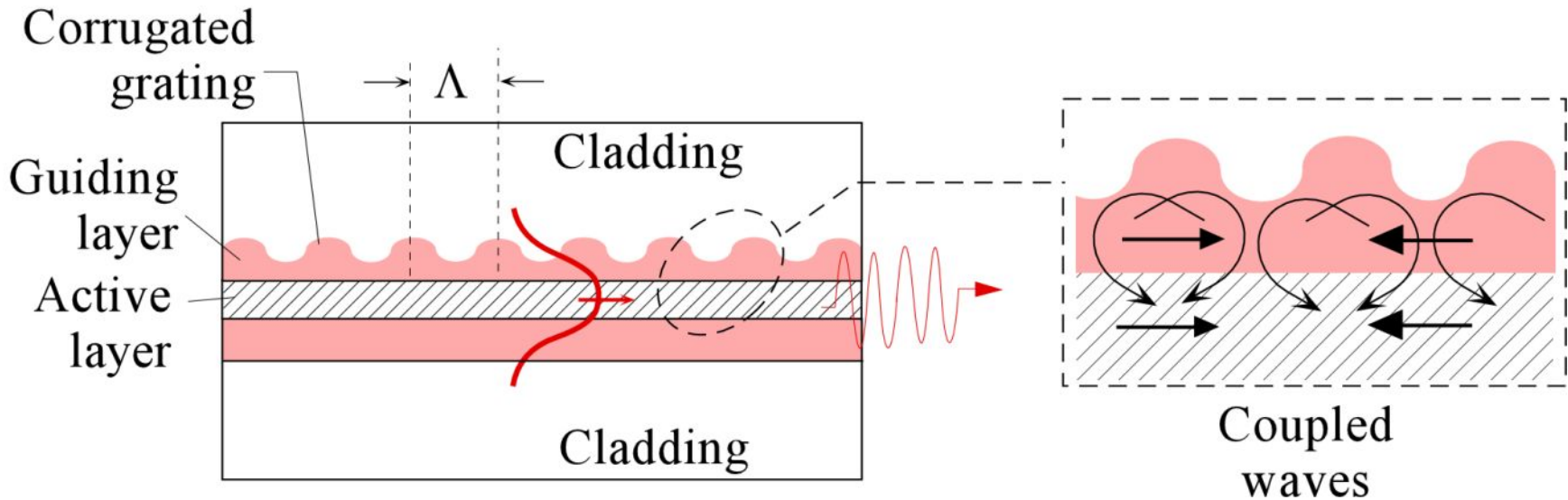

LEFT: Distributed feedback (DFB) laser structure. The mode field diameter is normally larger than the active layer thickness and the radiation spreads into the guiding layer.

RIGHT: There are left and right propagating waves, partial reflections from the corrugation, and optical amplification within the cavity, which has both the active layer and the guiding layer.

## Distributed Feedback (DFB) LDs

$$\lambda_m = \lambda_B \pm \frac{\lambda_B^2}{2nL} (m + 1)$$

Optical power (dB)

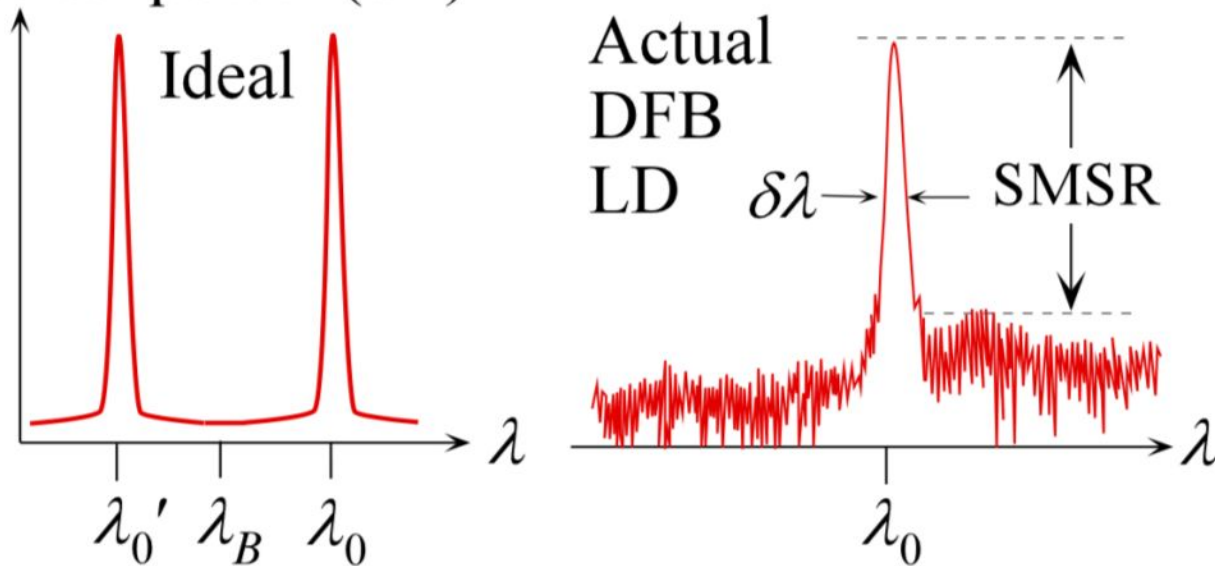

LEFT: Ideal lasing emission output has two primary peaks above and below  $\lambda_B$ . RIGHT: Typical output spectrum from a DFB laser has a single narrow peak with a  $\delta\lambda$  typically very narrow, and much less than 0.1 nm



## Distributed Bragg Reflector (DBR) and Distributed Feedback (DFB) LDs

**Selected properties of DBR, DFB and external cavity (EC) laser diodes**

**Note: fm is  $10^{-15}$  s;  $\delta\nu$  and  $\delta\lambda$  are spectral widths (FWHM). SMSR is the side mode suppression ratio, TEC is a thermoelectric cooler**

LD	$\lambda_0$ (nm)	$\delta\nu, \delta\lambda$ €	SMSR dB	$P_o$ mW	$I$ mA	$\eta_{\text{slope}}$ mA	Comment
DBR <sup>a</sup>	1063	2 MHz, 8 fm	45	80	200	0.8	GaAs DBR LD for spectroscopy and metrology, includes monitor current, TEC and thermistor.
DFB <sup>b</sup>	1063	2 MHz, 8 fm	45	80	190	0.2	GaAs DFB LD for spectroscopy and metrology, includes monitor current, TEC and thermistor
DFB <sup>c</sup>	1550	10 MHz, 0.08 pm	45	40	300	0.3	Pigtailed to a fiber, includes monitor current, TEC and thermistor. CW output for external modulation. For use in long haul DWDM.
DFB <sup>d</sup>	1653	0.1 nm	35	5	30	0.23	Pigtailed to a single mode fiber, includes monitor current, TEC and thermistor. Mainly for fiber optic sensing.
EC <sup>e</sup>	1550	50 kHz; 0.4 fm	45	40	300	0.2	Pigtailed. Tunable over $\Delta\nu = 3$ GHz. Mainly for communications

<sup>a</sup>Eagleyard, EYP-DBR-1080-00080-2000-TOC03-0000; <sup>b</sup>Eagleyard, EYP-DFB-1083-00080-1500-TOC03-0000;

<sup>c</sup>Furukawa-Fitel, FOL15DCWD; <sup>d</sup>Inphenix, IPDFD1602; <sup>e</sup>Covega SFL1550S, marketed by Thorlabs.



## Example: DFB LD wavelength

Consider a DFB laser that has a corrugation period  $\Lambda$  of  $0.22 \mu\text{m}$  and a grating length of  $400 \mu\text{m}$ . Suppose that the effective refractive index of the medium is  $3.5$ . Assuming a first order grating, calculate the Bragg wavelength, the mode wavelengths and their separation.

### Solution

The Bragg wavelength is

$$\lambda_B = \frac{2\Delta n \Lambda}{q} = \frac{2(1.5400)(0.22 \mu\text{m})}{1}(3.5)$$

and the symmetric mode wavelengths about  $\lambda_B$  are

$$\lambda_m = \lambda_B \pm \frac{\lambda_B^2}{2n\Lambda}(m+1) = 1.5400 \pm \frac{(1.5400)^2}{2(3.5)(400)}(0+1)$$

so that the  $m = 0$  mode wavelengths are

$$\lambda_0 = 1.53915 \text{ or } 1.54085 \mu\text{m}.$$

The two are separated by  $0.0017 \mu\text{m}$ , or  $1.7 \text{ nm}$ . Due to a design asymmetry, only one mode will appear in the output and for most practical purposes the mode wavelength can be taken as  $\lambda_B$ . Note: The wavelength calculation was kept to five decimal places because  $\lambda_m$  is very close to  $\lambda_B$ .



## External Cavity Laser Diodes (ECLD)

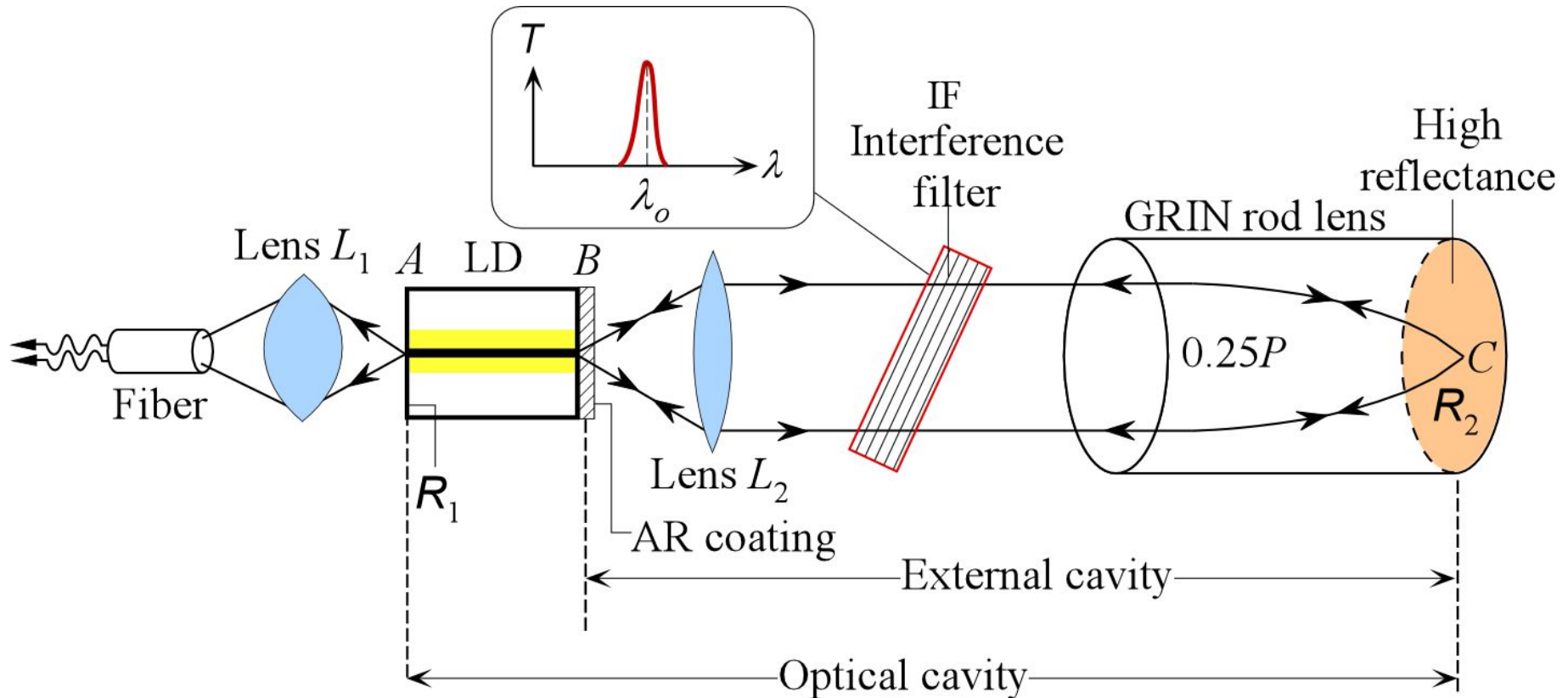

A simplified diagram of an external cavity diode laser (ECDL), which uses an angled interference filter (IF) to select the wavelength  $\lambda_0$  (depends on the angle of the IF), and the optical cavity has a GRIN lens with one end coated for full reflection back to the LD. The output is taken from the left facet of the LD.





## External Cavity Laser Diodes (ECLD)

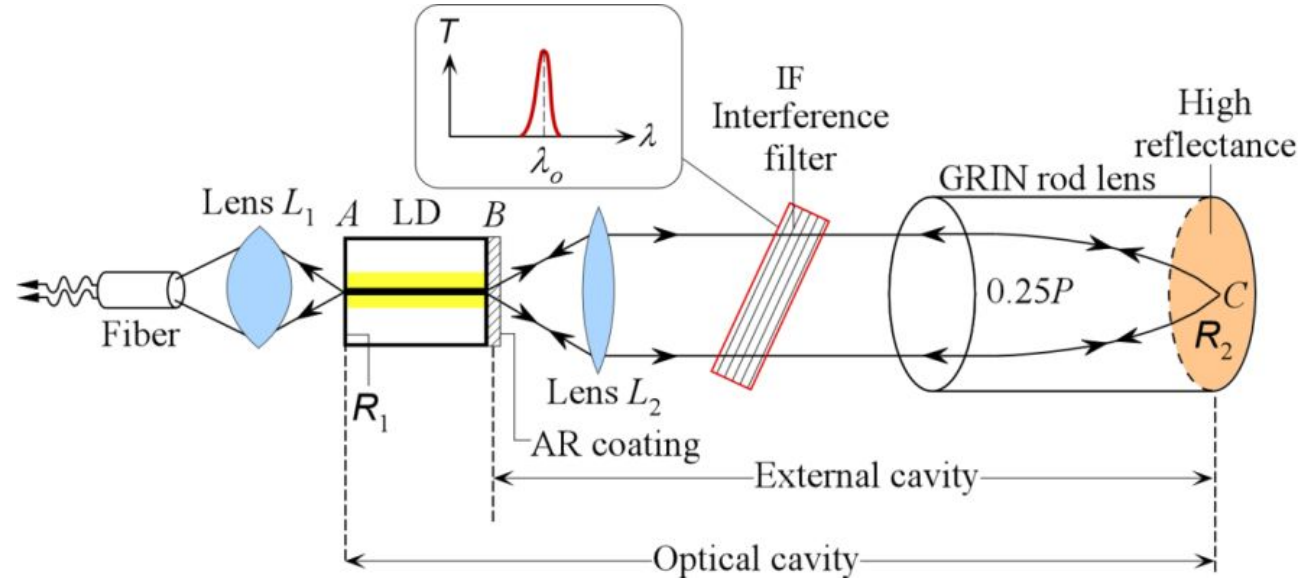

LEFT: A commercial external cavity diode laser, based on the principle shown on the right. (US Patent 6,556,599, Bookham Technology). The output is a single mode at 785 nm ( $\pm 1.5$  pm) with a linewidth less than 200 kHz, and coupled into a fiber. The output power is 35 mW, and the SMSR is 50 dB. (ECLD, SWL-7513-P. Courtesy of Newport, USA)